

ACC Series Chillers

Product Catalog

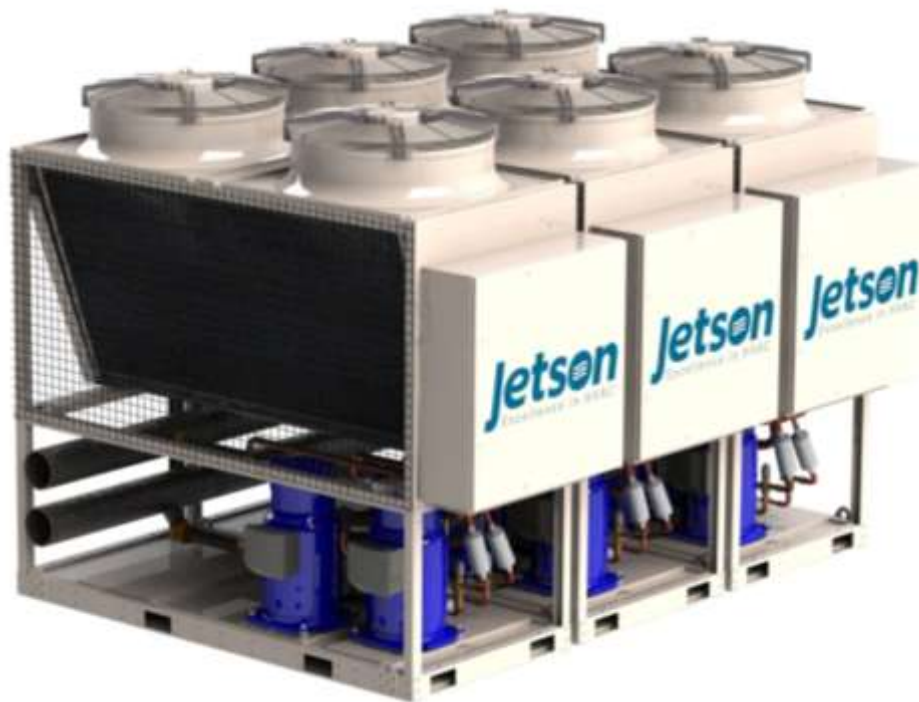

Jetson
by **MODINE**[®]

Contents

Features and Benefits	5
Application Information.....	10
Digit 4 — Chiller Type	23
Digit 5 to 7 — Nominal Capacity	23
Digit 8 — Unit Voltage.....	23
Digit 9 — Unit Application	24
Digit 10 — Steps of Capacity	24
Digit 11 — Refrigerant Type.....	24
Digit 12 — Efficiency.....	24
Digit 13 — Design Sequence.....	25
Digit 14 — Evaporator Heat Exchanger Type.....	25
Digit 15 — Evaporator Temperature Range	25
Digit 16 — Evaporator Flow and Valves	26
Digit 17 — Condenser Heat Exchanger Type	26
Digit 18 — Condenser Fan Control.....	26
Digit 19 — Condenser Heat Recovery	27
Digit 20 — Condenser Heat Recover Control Valves	27
Digit 21 — Power Connection.....	28
Digit 22 — Power Feed	28
Digit 23 — Service Options.....	28
Digit 24 — Control Style.....	29
Digit 25 — Local Unit Controller Interface	29
Digit 26 — Remote BMS Interface (Digital Comm).....	30
Digit 27 — Blank.....	30
Digit 28 — Refrigeration Options	30
Digit 29 — Refrigeration Accessories	30
Digit 30 — Water Connection	31
Digit 31 — Water Side Pressure.....	31
Digit 32 — Water Strainer(s).....	31
Digit 33 — Water Accessories	32
Digit 34 — Free Cooling	32
Digit 35 — Sound Attenuator	32
Digit 36 — Guards.....	32

Digit 37 — Exterior Finish and Shipping Splits 33

Digit 38 — Warranty 33

Digit 39 — Special Options 35

Literature Change History 36

Features and Benefits

Flexibility of Design

With model sizes ranging from 10 to 80 tons and configurable into arrays up to approximately 800 tons the ACC Series chiller can suit many applications. The installation of small chillers as needed is both more economically practical and energy efficient than a single large centralized chilled water plant, especially at part load and in application where chiller uptime and redundancy are important. For new installations or building renovations, the ACC Series easily allows large tonnage systems to be built with multiple smaller modules.

Because the ACC Series can be applied as an individual chiller or applied as a high capacity multi-stage, multi-chiller array by using the optional array controller package, the ACC Series chillers can be configured to meet capacity needs ranging from 10 tons to over 800 tons.

Convenience

The ACC Series chiller was designed with convenient installation and servicing in mind. The ACC Series chiller is delivered to the jobsite ready for installation and startup. Jetson offers a wide variety of standard and optional features, including single or dual circuit refrigeration systems and shell and tube or brazed plate evaporators. All of these components are piped, wired, and run tested before they are shipped from the factory. All models feature lockable, hinged access doors to the electrical components. Water connections are conveniently located to minimize the equipment's installed footprint and provide clear access to heat exchangers, filter driers and thermal expansions valves. Customer connections are 6-inch grooved pipe and arrive ready for immediate connection to the customer supply/return lines and, if

applicable, to other adjacent ACC Series modular chillers.

Reliability

The active freeze protection system on ACC chillers continuously monitors the suction temperature to prevent evaporator operation in freezing conditions. When suction pressure approaches freezing conditions the active freeze protection reacts to warm the evaporator. If the active freeze protection system can prevent a freezing condition the chiller will continue normal operation. If a freeze condition is imminent, the machine will lock out and provide an alarm. This system helps enhance the longevity of chiller operation and is included on all Jetson chillers. Core temperature sensors are installed in every ACC brazed-plate evaporator as a redundant low water temperature safety.

Jetson integrates the latest in scroll compressor technology into all of its products for improved operational reliability. Each chiller is factory inspected and checked for leaks before leaving the factory. Current transducer continuously monitors compressor amp draw and stop operation if excessive amps occur.

Every ACC modular chiller is run test before shipment, minimizing startup delay. A data log is retained at the factory for each unit shipped.

Quiet Operation

In addition to being dependable, the hermetic scroll compressors included in each ACC Series chiller offer quieter operation than comparable reciprocating compressors. Each compressor is placed on rubber isolator to minimize vibration. ACC Series chillers are available with compressor blankets and/or a sound enclosure. Sound enclosures fully enclose the compressors with sound dampening material to provide enhanced

sound reduction compared to sound blankets or non-isolated compressors.

Efficiency

The use of scroll compressors, while being both reliable and quiet, also boasts reduced frictional losses and improved efficiency over comparable reciprocating compressors. The ACC Series chiller maintains control on the leaving water temperature by cycling compressors on and off at part load conditions, maintaining efficient operation across the entire range of operation. All ACC Series chillers meet or exceed ASHRAE 90.1 – 2019.

Serviceability

Standard, integral valving makes it possible to isolate the ACC heat exchangers for routine maintenance. Once isolated, water-to-refrigerant heat exchangers have inlet and outlet grooved pipe connections readily accessible to allow for backflushing, chemical cleaning without having to remove the exchanger.

Smart Controls

Every model is furnished with a microprocessor controller that cycles the compressors to maintain the leaving water temperature over a wide range of operating conditions. A convenient alphanumeric LCD display that is updated once per second. Inputs are made using large function keys with menu driven prompts. Schedules are available with a seven-day built-in time clock. Terminals are provided for remote stop-start and for remote reset of the leaving water temperature setpoint. The controller features 12 analog and 4 digital inputs as well as 4 analog outputs. Nonvolatile memory is used for all control functions. Additional optional features include diagnostic sensors for pressure and temperature on each refrigerant circuit, current sensors for each compressor, and a RS-485 port allowing communication with other manufacturer's control systems.



Figure 1 -Keypad Controller Display

Building Communications

When the ACC Series chiller is used in conjunction with a building management system (BMS), the chiller can be monitored and given input from a remote location. The chiller can be set up to fit into the overall building control strategy by using remote run/stop input, remote demand limit reset and/or remote chilled water reset functions.

As standard, the unit controller Ethernet port is always ready to talk BACnet® IP and Modbus™ TCP/IP (Modbus RTU uses the RS485 network port). BACnet® MS/TP, Johnson N2 and LonTalk® are optional protocols that can be factory-installed. The unit controller can facilitate hundreds of control points, including the following popular BMS communications:

- Remote Off/Auto signal (input from BMS)
- Demand Limit Reset signal (input from BMS)
- Chilled Water Temperature Reset signal (input from BMS)
- Customer Alarm relay (view only)
- Chiller Run Indication (view only)
- Entering Chilled Water Temperature (view only)

- Leaving Chilled Water Temperature (view only)
- Chilled Water Flow Switch input (view only)
- Condenser Pump relay (view only)
- Chilled Water Pump relay (view only)

System Protection

A complete safety lockout system with alarms protects the ACC Series chiller operation to potentially avoid compressor and evaporator failures. The unit controller directly senses pressures, temperatures, amperage, motor faults, etc. All control variables that govern the operation of the chiller are evaluated every second for exact control and protection. The following is an abbreviated list of safeties that are incorporated into the standard chiller algorithm control.

- **No Flow Protection** – To protect the chiller from no water flow to the evaporator, the chiller is enabled to run only if the required flow proving device indicates there is flow present. If the chiller is active and flow is lost; the chiller will lock out and an alarm is generated.
- **Low Suction Pressure** – To protect the compressors and evaporator, if the refrigerant suction pressure drops below the set point value for a specified period of time, a safety trip occurs. This safety is bypassed when the compressor is in a Pump Down state.
- **Unsafe Suction Pressure** – To protect the compressors and evaporator, if the refrigerant suction pressure drops below the set point value for a specified period of time, the chiller will immediately lock out, and an alarm is generated.
- **Heat Exchanger Freeze Protection** – To protect the evaporator from low water temperatures, the chilled water

temperature is monitored inside the core of the evaporator and leaving the evaporator. If these temperatures fall below their set point temperatures for the set period of time, the entire system will lock out and an alarm is generated.

- **Active Freeze Protection System** – Working in conjunction with the low suction pressure and freeze protection safeties to avoid nuisance safety trips, the active freeze protection valve is opened when the suction pressure goes below the lower set point value and warms the evaporator until the freeze conditions are abated. The valve will stay open until the suction pressure rises safely above the upper set point level.
- **High and Low Discharge Pressure, High and Low Superheat, High and Low Compressor Amps** – The compressors will be locked out if any one of these control variables rises above the upper set point value or falls below the lower set point value for the set amount of time for each, and an alarm is generated.
- **Optional Phase/Power Monitor** – The factory-installed phase/power monitor continuously monitors the incoming power supply to the chiller for low voltage, phase rotation reversal, loss of phase and phase imbalance. Should one of these parameters be incorrect, the phase/power monitor relay will lock out (de-energize) and the fault LED on the monitor will blink. The unit controller will indicate the lockout, and an alarm is generated.

As an additional layer of system protection, mechanical high- and low-pressure switches are used in conjunction with the refrigerant circuit high- and low-pressure transducers and unit controller.

Standard Peripheral Control Features

The following peripheral control features and program logic come standard on all ACC Series chillers. Designated terminals on the field connection terminal strip in the control panel are provided for field connection of:

- **Remote Off/Auto** (dry contact closure from a remote device - input)
- **Required Chilled Water Flow Proving Device** (dry contact closure from a remote device - input)
- **Remote Alarm** (dry contact closure to a remote device - output)
- **Required Chilled Water Pump Enable** (dry contact closure for 1 chilled water pump - output)
- **Condenser Water Pump Enable** (dry contact closure for 1 condenser water pump - output)

Standard Capacity Control

Standard capacity control on the ACC Series chillers is accomplished by staging the scroll compressors on and off. The unit controller will maintain a set point leaving chilled water temperature within a control zone using proportional, integral derivative (PID) logic. If the leaving chilled water temperature starts to decrease and falls below the set point, the unit controller will turn one stage off. A further reduction in temperature will result in a second stage being turned off. The reverse is true as the leaving chilled water temperature increases. Lead/lag logic is used to even the run time on the individual compressors.

Optional Capacity Control

Chilled water temperature reset can be accomplished in two ways. In buildings with a building management system, the ACC Series unit controller allows the BMS to communicate an offset to the chilled water temperature set point. If a BMS is not being used, the unit controller can accept a field provided 0 to 5 VDC analog input signal. As the input voltage varies away from center

(2.5V), the chilled water temperature set point will be offset proportionally.

Note: This control logic is factory-installed and must be denoted at the time of ordering.

Demand limiting is a form of capacity control that limits the number of capacity steps the compact chiller is allowed to operate. It can be accomplished in the same two ways as the chilled water temperature reset: through BMS or field-provided 0 to 5 VDC input signal.

Note: This control logic is factory-installed and must be denoted at the time of ordering.

Array Control

The array controller option allows the ACC Series chiller to be an ideal solution for facilities with growing occupancy and structural expansion plans because chillers can be added as capacity needs increase or applications where convenient redundancy is needed.

ACC Series air-cooled chiller arrays can be controlled by two different array controller configurations, depending on the needs of the application. Both options allow the array to be controlled and operated like a single, higher capacity, multistage chiller. Capacity modulation and equalization of compressor run time is managed by the array controller. The array controller uses the same standard capacity control logic as an individual ACC unit controller but with more stages of capacity.

Supervisory Array Controller

This option allows up to ten (10) ACC Series chillers to be controlled and operated. The Supervisory Array Controller requires each module have an individual unit controller. This option is beneficial in applications requiring seven (7) or more modules to be controlled and in applications where chiller uptime is critical.

Power (115VAC) must be provided to a circuit breaker inside the Supervisory Array Controller enclosure panel to power the Supervisory Array Controller. The Supervisory Array Controller enclosure also contains a field connection terminal strip and door-mounted off/auto switch, run indicator light and alarm indicator light.

The Supervisory Array Controller is accessed in the same manner as the unit controller, through the keypad display or PC/laptop. If communication between the individual ACC Series chiller unit controller(s) and the Supervisory Array Controller is lost, or the Supervisory Array Controller fails, the individual ACC Series chillers can be shifted into manual mode to operate independent from the Supervisory Array Controller and will maintain a “manual mode” default chilled leaving water temperature set point.

N+1 logic can be utilized with the Supervisory Array Controller when each chiller in an array is equipped with optional chilled water motorized on-off valve, optional condenser water regulating valve and a standby chiller is installed in the array.

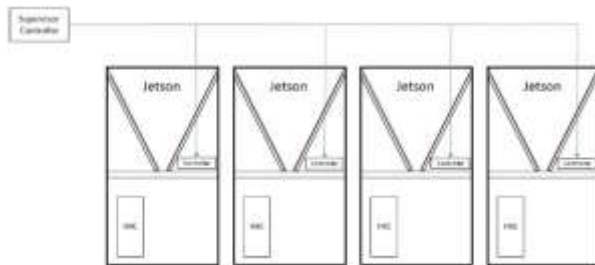

Figure 2 - Supervisor Controller Layout

Master-Secondary Array Controller

This option allows up to six (6) ACC Series chillers to be controlled and operated. The Master-Secondary Array Controller requires only a single controller for the array. This option is beneficial in replacement applications where a single larger chiller, with one controller, is replaced by modular chillers

controlled with one controller. The Master-Secondary Array Controller is also applicable for chiller applications that do not require redundant operation and first cost is considered an important factor.

The Master-Secondary Array Controller is powered from the unit supply power and factory provided transformer or low voltage power supply. The Master-Secondary array control panel also contains a field connection terminal strip and door-mounted off/auto switch, run indicator light and alarm indicator light.

The Master-Secondary Array Controller is accessed through the keypad display, touchscreen display or PC/laptop. If communication between the individual ACC Series chiller modules and the Master-Secondary Array Controller is lost, that module will be inoperable until communication to the module is restored. The Master-Secondary Controller will continue to control the other modules in the array. If Master-Secondary Array Controller fails, the array will be down until the controller is repaired or replaced.

N+1 logic can be utilized with the Master-Secondary Array Controller, via the demand limit function, when each chiller in an array is equipped with optional chilled water motorized on-off valve, optional condenser water regulating valve and a standby chiller is installed in the array.

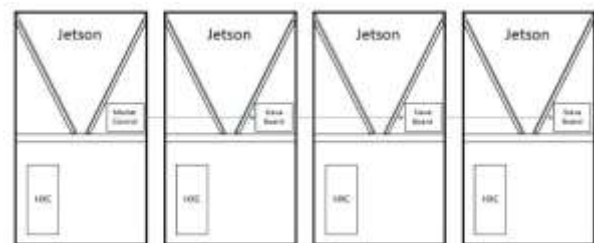

Figure 3 - Master-Secondary Controller Layout

Application Information

Unit Sizing

See JESS (Jetson Engineering Selection Software) for unit capacities. Intentionally over-sizing a unit to assure adequate capacity is not recommended. Erratic system operation and excessive compressor cycling are often a direct result of an oversized chiller. In addition, an oversized unit is usually more expensive to purchase, install, and operate. If oversizing is desired consider using two smaller units.

Altitude Effect

At elevations substantially above sea level, the decreased air density will decrease condenser capacity and, therefore, unit capacity and efficiency.

Evaporator Design Data

The system can start and pull down with up to 90°F entering fluid temperature. For continuous operation, it is recommended that the entering fluid temperature not exceed 75°F. The maximum sustained leaving chilled-fluid temperature is 65°F. The chiller with *standard* evaporator must not be operated with a leaving water temperature of less than 42°F for a plain water application. The chiller with *high capacity* evaporator must not be operated with a leaving water temperature of less than 40°F for a plain water application. For evaporator loops containing the appropriate amount of glycol, the chilled water leaving temperature range can be shifted to 15°F to 65°F. When lower leaving fluid temperatures are required, an appropriate glycol solution must be used. The solution must have a freezing point at least 15°F lower than the design leaving fluid temperature. The brine solution must also be properly inhibited to provide suitable corrosion protection.

In general, the listed flow rate ranges will develop temperature differentials across the evaporator between 7°F to 20°F. If your

application conditions do not fit these requirements, please contact Jetson Innovations.

For all ACC Series chiller applications, the flow to the evaporator must be proven using a chilled water flow-proving device. A factory-provided paddle style liquid flow switch is provided with a NEMA Type 4X enclosure for field-installation.

Heat Recovery Condenser Design Data

Standard condenser entering water temperature range for the ACC Series chiller is 65°F to 115°F. The condenser leaving water temperature (LWT) maximum is 140°F for brazed-plate condenser, and the condenser LWT minimum is 70°F. When the condenser LWT is lower than 70°F, the refrigerant condensing temperature can drop below 80°F and fall outside of the ACC Series compressor's operating envelope. For these applications, provisions must be made to control the condenser water that results in a stable refrigerant condensing temperature / pressure that remains above 80°F (235 psig) throughout all steady state, part load and transient operating conditions. Low leaving condenser water temperatures are not typical in heat recovery applications because the condenser heat is used to satisfy a heat load in the building or process.

In general, the listed flow rate ranges will develop temperature differentials across the condenser between 5°F to 30°F. If your application conditions do not fit these requirements, please contact the Jetson Innovations.

Jetson modular air-cooled chillers may have one, two, three or four compressors in each individual module. All compressors are served by common water flow. In a typical application with nominal water flows of 2.4 gpm/ton through the evaporator BPHE (brazed plate

heat exchanger) the delta temperature entering and leaving the heat exchangers will be 10°F with full capacity per circuit (one compressor on single compressor per circuit, two compressors on tandem compressor per circuit) and 5°F with half of the capacity running.

Condenser Heat Recovery Operation

At a time when energy costs are high and continue to rise, reducing energy usage has become increasingly important. By using an ACC Series chiller with heat recovery, utilization of energy can be improved by using heat from the condenser that would otherwise be wasted.

The use of heat recovery should be considered in any building with simultaneous heating and cooling requirements or in facilities where heat can be stored and used at a later time. Buildings with high year-round internal cooling loads are excellent opportunities for heat recovery. Heat recovery can be accomplished with the ACC Series by recovering heat that would have otherwise been rejected to via the air-cooled condenser and instead using it to serve a heating load. *Figure 4 - Heat Recovery.*

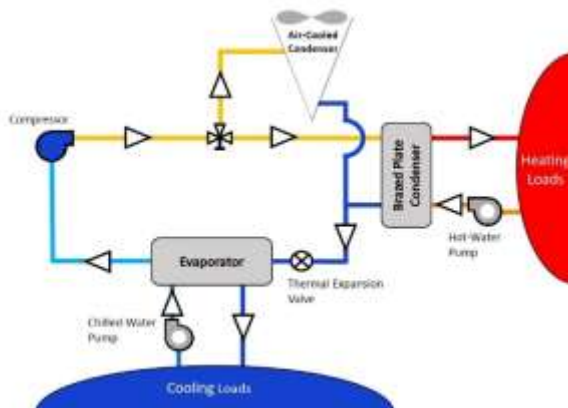

Figure 4 - Heat Recovery

Heat recovery is designed to capture a portion of the heat that is normally rejected to the air-cooled condenser and put it to beneficial use. With the addition of a heat recovery cycle, heat

removed from the building cooling load can be transferred to any heating application. The heat recovery cycle is only possible if a cooling load exists to act as a heat source.

Hospitals, dormitories, computer centers, and hotels are opportunities for economical heat recovery due to their needs for hot water for reheat and domestic use, coupled with air-side economizer operation, or in some cases, winter operation of chillers. Heat recovery provides hot water and tight control that minimizes operating costs for the chilled water plant and boiler/hot water heater, while also providing consistent dehumidification. The heat recovery heat exchanger cannot operate alone without a load on the chiller.

Units with a brazed plate heat recovery heat exchanger can produce up to 140°F leaving water temperature.

Fluid Volume

Consideration must be given to the total volume of fluid in the system. In close coupled, low volume systems, the leaving fluid temperature will change quickly with steps of capacity control. This is not acceptable if close control is desired for a conditioned space or an industrial process. In order to accurately determine the fluid volume needed for the application, you must resolve and agree on the amount of swing in fluid temperature that can be tolerated. This will depend on the control system, the terminal equipment operation, and use. For applications utilizing constant flow evaporators, 25% of the design load is the minimum array turndown allowed. If further turndown is required, the system must have variable primary flow and motorized isolation valves on each chiller module.

The ACC Series chillers contain 1, 2, 3 or 4 compressors per module, and can be configured in arrays containing up to 20 compressors. Use the following example as a guide to determine swing in fluid temperature tolerable.

Use the information in *Table 1 Minimum Volume* that lists the maximum step of capacity in each array and a factor for that model.

FLUID VOLUME EXAMPLE

Problem: An array of three (3) ACC 40-ton units has a total rated tonnage of $38.6 \times 3 = 115.8$ tons at the operating conditions. Each module has two compressors each, for a total of 6 compressors. The chilled water flow is constant volume. It is desired to have no greater than a $\pm 3^\circ\text{F}$ leaving water temperature variation due to compressor unloading. What is the minimum water volume required in the chilled water loop?

Solution: We use the following equation to determine the minimum allowable water loop volume.

$$\text{Minimum Water Loop Volume} = \frac{\text{Actual Tons} \times (\text{Min. Volume Gal-}^\circ\text{F Swing/Ton})}{\text{Allowable } ^\circ\text{F Swing}}$$

Allowable $^\circ\text{F}$ Swing is specified in the problem statement. With a tolerance of $\pm 3^\circ\text{F}$, the total allowable swing is 6°F .

We select the value of Min. Volume Gal- $^\circ\text{F}$ Swing/Ton from Table 1 Minimum Volume based on the number of compressors in the array and the type of flow.

Table 1 Minimum Volume

Number of on/off compressors in array	Maximum % Capacity Step	Minimum Volume (Gal- $^\circ\text{F}$ Swing)/ton
1	100.0%	120.0
2	50.0%	60.0
3	33.3%	40.0
4	25.0%	30.0
5	20.0%	24.0
6	16.7%	20.0
7	14.3%	17.1
8	12.5%	15.0
9	11.1%	13.3
10	10.0%	12.0
11	9.1%	10.9
12	8.3%	10.0
13	7.7%	9.2
14	7.1%	8.6
15	6.7%	8.0
16	6.3%	7.5
17	5.9%	7.1
18	5.6%	6.7
19	5.3%	6.3
20	5.0%	6.0

** 25% is the lowest capacity step allowed for constant flow arrays.*

For a six-compressor array, the maximum capacity step is 16.7%, therefore the Minimum Volume = 20 (Gal - °F deg F Swing)/ton

Thus, we can compute the minimum water loop volume with the known performance of 115.8 tons of cooling at the application conditions:

$$\text{Minimum Water Loop Volume} = 115.8 \text{ tons} \times (20 \text{ Gal} - \text{°F Swing})/\text{ton} / 6 \text{ °F swing} = 386 \text{ gallons.}$$

Gallons per Ton

Using the minimum turndown of 25% for constant volume systems, this equation can be generalized to a commonly used guideline: *gallons per ton* loop volume. By tabularizing different allowable °F swings the minimum volume on a gallon per ton basis can be displayed.

Table 2 Minimum Volume (Gallon/Ton)

Allowable temp. swing above & below setpoint (+/-°F)	Minimum Volume (gallon/ton)
5.0	3.00
4.5	3.33
4.0	3.75
3.5	4.29
3.0*	5.00
2.5*	6.00
2.0*	7.50
1.5	10.00
1.0	15.00
0.5	30.00

* Common value used in HVAC industry

Loop Time

This same detailed equation can be generalized to another common loop volume sizing method: *loop time*. As a general guideline, a minimum 3-minute loop time is required for the evaporator chilled water system. In a typical application, the nominal fluid flow through the evaporator is 2.4 gpm/ton.

At nominal flows, a 3-minute loop time is equivalent to a minimum loop volume of 7.2 gallon/ton (2.4 gpm/ton x 3 min = 7.2 gallon/ton) and would have an allowable leaving fluid temperature swing of +/- 2.1°F

At nominal flows, a 2-minute loop time is equivalent to a minimum loop volume of 4.8 gallon/ton. (2.4 gpm/ton x 2 min = 4.8 gallon/ton) and would have an allowable leaving fluid temperature swing of +/- 3.1°F.

Notice, in the preceding example, if this system was selected for a 45°F leaving water temperature, the temperature will vary between 42°F to 48°F (recall the variation tolerance +/- 3°F) with the cycling of the compressors at the water loop volume of 641 gallons. The final selection should ensure the leaving water temperature does not drop below 42°F (or 40°F if using a high capacity evaporator). If a leaving water temperature below 42°F (or 40°F if using a high capacity evaporator) is indicated then the loop volume should be increased or glycol should be included with the design.

Glycol

If the fluid loop contains glycol, the required water loop volume should be multiplied by the correction factor in *Table 3 Glycol Correction Factors*.

Table 3 Glycol Correction Factors

% by Weight	Glycol Volume Correction Factor	
	Ethylene	Propylene
10	1.038	1.017
20	1.066	1.033
30	1.100	1.058
40	1.140	1.092
50	1.192	1.142

It may be necessary to install a storage tank in the system to provide the necessary volume for close temperature control. A volume buffer tank should be located in the return water

pipings. *Figure 5 Expansion Tank Usage* illustrates a proper volume buffer tank usage.

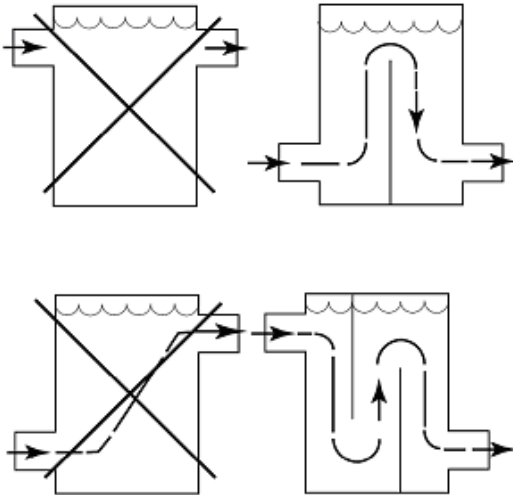

Figure 5 Expansion Tank Usage

Variable Flow

ACC Series chillers can be applied in variable flow applications where the flow is varied and controlled by others. The flow being delivered to the chiller must not go outside the stated minimum and maximum flow rates in **Error! Reference source not found.**. Also, the chilled water system volume should be calculated using the highest evaporator flow rate to be delivered to the chiller, and the rate of change in flow rate must not exceed 10% of design flow gpm per minute.

In ACC Series chiller arrays, the chillers are piped with a common header. Notice in *Figure 6. Variable Flow with Parallel Pumps* this common header arrangement allows the ability to operate the system in several ways depending on the load and/or current situation. For instance, the system can be operated with two pumps and one chiller so that flow out into the system can be increased, without needing to stage on an additional chiller.

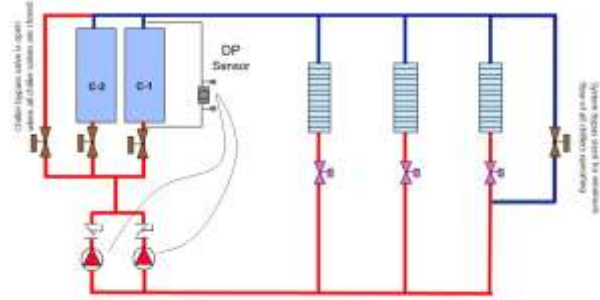

Figure 6. Variable Flow with Parallel Pumps

This configuration also allows flexible redundancy with commonly headered pumps and chillers. If a pump goes down, the remaining pump can serve one or both chillers and still meet the required load. If a chiller needs service or is turned off, the system can compensate for some of the loss in capacity by increasing flow through the remaining chiller while operating both pumps. However, the flow being delivered to any chiller must not go outside the stated minimum and maximum flow rates.

By maintaining the flow between the minimum and maximum flow rates, the chiller is able to provide proper heat transfer and stable operation at lower flows and avoid eroding the pipes at higher flows.

Variable Flow Bypass Valves

A bypass valve is required at the chillers and the load (air handlers, terminal devices, etc.) in systems with variable flow pumping. The bypass must be piped so the temperature and differential pressure sensors are always sensing active flow.

Load Bypass Valve

If a single load side bypass valve is used, it should be sized to bypass the minimum water flow at *maximum* chiller load. This size is required because there can be a lag between the load measured at the system load and at the ACC Series chiller bank. This lag can create

different flow requirements at the load versus the chiller(s).

An example of this lag is when a building becomes occupied in the morning and the chillers are in a pull-down situation. The air handlers serving the occupied space reach the desired occupied temperature and simultaneously drive their control valves closed. At the same time, the chillers are still in a pull-down mode and running at full capacity to reach the desired leaving water temperature. As a result, the chiller(s) require more flow than the rest of the system until the chiller controls unload the chiller to match the new system load condition. Without a system bypass valve, the system pump(s) will either provide too much flow to the load (air handlers, terminal devices, etc.) or not enough flow the chiller array. The bypass valve also ensures that there is an adequate minimum flow thru the pump if all the valves in the load system are closed, otherwise the pumps can deadhead.

Bypass valves at the end of the loop/system, as shown in *Figure 7. Example Load Bypass Valve Arrangements*, promotes keeping the overall active loop volume high. Some systems may not allow for an end-of-loop bypass. In these situations, the bypass valve may be installed closer to the chiller, provided the minimum system volume equaling a minimum of a 2-3 minute loop time is maintained to ensure proper operation. (See section on “Loop Time” in this catalog for more information.)

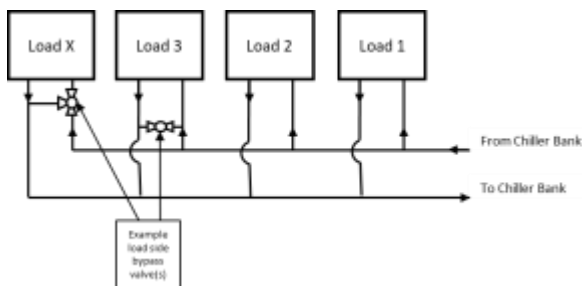

Figure 7. Example Load Bypass Valve Arrangements

External Chiller Array Bypass Valve

A bypass valve for the chiller array is required so that when the chiller array has reached the desired leaving water temperature, and the motorized valves for each module have closed, system flow remains through the external chiller array bypass valve. The chiller bypass should be sized for the minimum flow of one chiller module or the minimum flow of the system’s pumping system, whichever is greater. This bypass is only required to be open when all motorized valves in the chiller array are closed. After the first module is active and the motorized valves are the open, the external chiller array bypass valve can be closed because the active module now provides the water flow path.

Ice Storage

An ice storage system uses the chiller to make ice at night when utility rates are lower. The stored ice reduces or even replaces mechanical cooling during the day when utility rates are at their highest. This reduced need for cooling results in significant utility cost savings and source energy savings.

Another advantage of an ice storage system is its ability to eliminate chiller oversizing. A “rightsized” chiller plant with ice storage operates more efficiently with smaller support equipment while lowering the connected load and reducing operating costs. Best of all, this system still provides a capacity safety factor and redundancy by building it into the ice storage capacity for practically no cost compared to oversized systems.

Jetson air-cooled chillers are suited to low temperature applications like ice storage because of the ambient relief experienced at night. Chiller ice making efficiencies are typically similar to or even better than standard cooling daytime efficiencies as a result of nighttime dry-bulb ambient relief.

Standard control strategies for ice storage systems are another advantage of the ACC chiller. The dual mode control functionality is integrated right into the chiller.

Water Circuit Requirements

ACC Series modular chillers are equipped with brazed plate evaporators. The water/fluid circuits to be used with these chillers should be designed and installed following sound engineering practices and procedures as well as any applicable local and industry standards. For the brazed plate heat exchanger circuits, focus on proper filtration and water quality is necessary. Prior to connecting an ACC Series modular chiller into a newly installed or existing water piping system, it is required to flush the system with a detergent and hot water mixture to remove previously accumulated dirt and other organics. In old piping systems with heavy encrustation of inorganic materials, a water treatment specialist should be consulted for proper passivation and/or removal of these contaminants.

Filtration

Particulate fouling is caused by suspended solids (foulants) such as mud, silt, sand or other particles in the heat transfer medium. The best way to avoid particulate fouling is to have good water treatment and keep all system water clean and with open loop system water, maintain proper bleed rates and make up water. A strainer with a 20-mesh screen (or screen with 0.5 mm sized openings or less) is required to be installed at the individual compact chiller (or compact chiller array) inlet to protect the brazed plate heat exchangers. Wye-strainers are available as a factory-provided, field-installed option. If an application is highly susceptible to foulant contamination, additional filtration methods should be investigated.

Water quality

Poor water quality can cause another type of fouling called scaling. Scaling is caused by inorganic salts in the water circuit of the heat exchangers. Scaling increases pressure drop and reduces heat transfer efficiency. The likelihood of scaling increases with increased temperature, concentration and pH. In addition to scaling, poor water quality can cause other issues like biological growths and corrosion. Therefore, water quality and water quality control need to be an application consideration. Please review the water quality requirements for use with the brazed plate heat exchangers on the ACC Series modular chiller.

Table 4 Water Property Limits

Water Property	Concentration Limits
Alkalinity (HCO ₃ ⁻)	70-300 ppm
Sulfate (SO ₄ ²⁻)	Less than 70 ppm
HCO ₃ ⁻ / SO ₄ ²⁻	Greater than 1.0
Electrical Conductivity	10 - 500 µS/cm
pH	7.5 – 9.0
Ammonia (NH ₃)	Less than 2 ppm
Chlorides (Cl ⁻)	Less than 300 ppm
Free Chlorine (Cl ₂)	Less than 1 ppm
Hydrogen Sulfide (H ₂ S)	Less than 0.05 ppm
Free (aggressive) Carbon Dioxide (CO ₂)	Less than 5 ppm
Total Hardness (°dH)	4.0 - 8.5
Nitrate (NO ₃)	Less than 100 ppm
Iron (Fe)	Less than 0.2 ppm
Aluminum (Al)	Less than 0.2 ppm
Manganese (Mn)	Less than 0.1 ppm

Oversizing Chillers

Generally speaking, fully loaded equipment operates more efficiently than large equipment running at or near minimum capacity. When selecting a chiller, the anticipated part load operation of the system should be evaluated with respect to the NPLV rating of the equipment under consideration. Larger future loading requirements may cause temporary oversizing of equipment that is initially selected and installed. This should be done with care, although the ACC Series array

chiller, with multiple scroll compressors, is more tolerant than designs that use a single compressor or a few larger compressors.

Chiller Placement

The ACC Series air-cooled chillers are designed for outdoor installations that remain above -20°F and below 115°F at all times. Locate the chiller away from sound-sensitive areas on a level foundation or base strong enough to support 150 percent of the operating weight and large enough to keep with service clearances. Also, the chiller foundation or base must be rigid enough to minimize vibration transmission. Please see General Data tables for sound data and Dimension and Weights information for unit operating weights and clearances. If necessary, options are available for sound attenuation and vibration reduction.

Structurally transmitted sound can be reduced by elastomeric vibration eliminators. Elastomeric isolators are generally effective in reducing vibratory noise generated by compressors, and therefore, are recommended for sound sensitive installations. An acoustical engineer should always be consulted on critical applications.

For maximum isolation effect, water lines and electrical conduit should also be isolated. Wall sleeves and rubber isolated piping hangers can be used to reduce the sound transmitted through water piping. To reduce the sound transmitted through electrical conduit, use flexible electrical conduit.

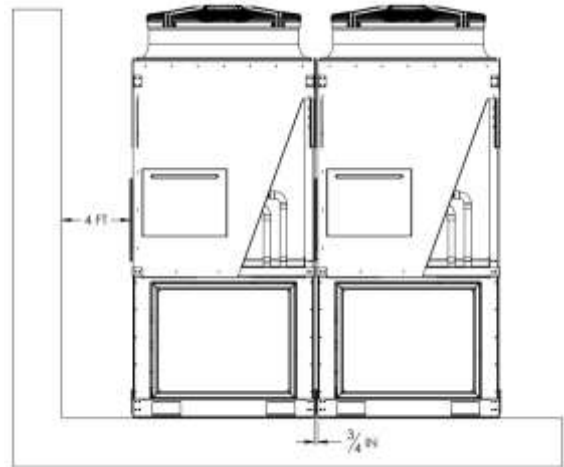

Figure 8- Required Clearance from Wall

Condenser Air Flow

Unobstructed flow of condenser air is essential to maintain chiller capacity and operating efficiency. When determining unit placement, careful consideration must be given to assure a sufficient flow of air across the condenser heat transfer surface. Two detrimental conditions are possible and must be avoided: warm air recirculation and coil starvation. Air recirculation occurs when discharge air from the condenser fans is recycled back to the condenser coil inlet. Coil starvation occurs when free airflow to the condenser is restricted. Condenser coils and fan discharge must be kept free of snow or other obstructions to permit adequate airflow for satisfactory unit operation. Debris, trash, supplies, etc., should not be allowed to accumulate in the vicinity of the air-cooled chiller. Supply air movement may draw debris into the condenser coil, blocking spaces between coil fins and causing coil starvation. Both warm air recirculation and coil starvation cause reductions in unit efficiency and capacity because of the higher head pressures associated with them.

Unit-to-Unit Placement

The installation position must provide at least sufficient clearance for proper airflow to the condenser coils. See Table 5 for individual unit clearances. When units are mounted adjacent to each other, as in a modular array, the minimum clearance required between the units is ½”.

Walled Enclosure Installations

When the unit is placed in an enclosure or small depression, the top of the surrounding walls should be no higher than the top of the fans. The chiller should be completely open above the condenser fans. There should be no roof or structure covering the top of the chiller. Ducting individual fans is not recommended.

Low Ambient Wind Placement

Cross winds, those perpendicular to the condenser, tend to aid efficient operation in warmer ambient conditions. However, they tend to be detrimental to operation in lower ambient temperatures due to the accompanying loss of adequate head pressure. Special consideration should be given to low ambient units. As a result, it is advisable to protect air-cooled chillers from continuous direct winds exceeding 10 mph in low ambient conditions. Be sure to observe the dimensions that are on the rating plate of the chiller for operational and service clearances.

Table 5 - Service Clearance

Location	Required**	Recommended
Back	0”	96” for coil removal
Front*	42”	48”
Left	0”	48”
Right	0”	48”
Top	unobstructed	unobstructed

*Front = facing controls enclosure

** Local code may take precedence

Mounting Isolation

Anytime vibration transmission may be a factor, vibration isolators may be considered. Rubber isolators are available as factory provided options.

Electrical Power Supply

A disconnect switch that is accessible from the outside of the cabinet is an available option factory installed. The microprocessor controller furnished with the unit is supplied with its own power supply factory wired to the main power of the chiller. The voltage to the chiller must be within plus or minus 10% of the nameplate rating value on the unit. All ACC Series chiller arrays are available with a single point power supply or each module may be powered individually. The largest capacity single point power supply terminal supplied from Jetson is rated at 1200 amps.

Optional Oversized Evaporator

These heat exchangers may be selected for improved performance with water or they may be selected for use with systems that contain glycol to aid in offsetting the decreased capacity due to the thermal properties of glycol. Oversized evaporators also allow a 40°F leaving water temperature without the requirement for glycol.

Multiple Chiller Applications

When more than one (1) ACC Series chiller is piped together (to form an array of chillers) for higher capacity and/or redundant chiller applications, an array controller package must be provided from the factory. A Master-Secondary controller can control up to six (6) units in an array. A Supervisor controller can control up to ten (10) units in an array.

The number of compact chillers that can be physically piped together to form an array and share a common header is limited to approximately 800 total tons or 960 gpm. In general, if the total tonnage is 400 tons or less

or 960 gpm or less, one common evaporator supply/return line and one common condenser supply/return line can be used. If the total tonnage needed is greater than 400 tons or 960 gpm, the flow from these common lines can be split between two arrays of chillers. Array water line sizing is based on a 2.4 gpm per ton

evaporator flow and a velocity limitation of 10 feet per second. *Figure 10* – shows examples of acceptable array piping configurations. For help with determining the most effective array configuration for your application, please contact the factory.

*With split header array piping, the limitation of 10 units is based on the controller capability, not the flow velocity limit of 10fps.

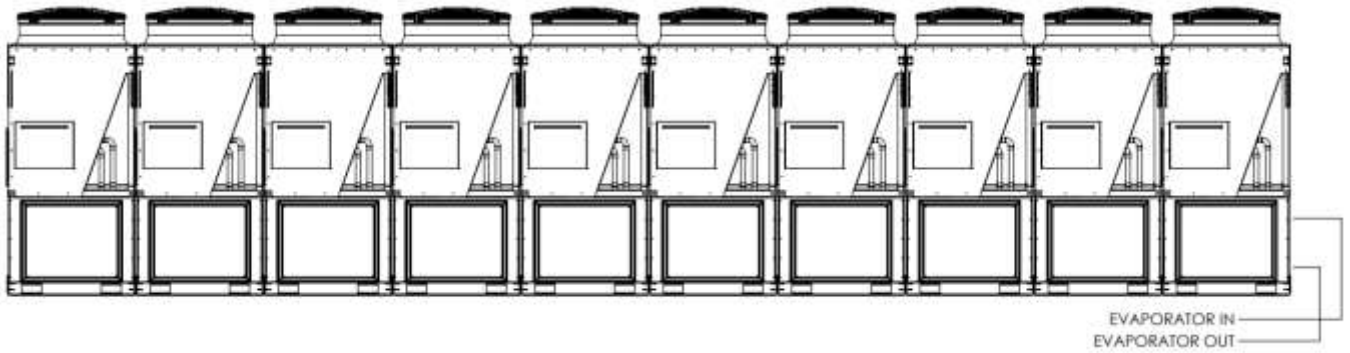

Figure 9 - Common Supply / Return Line

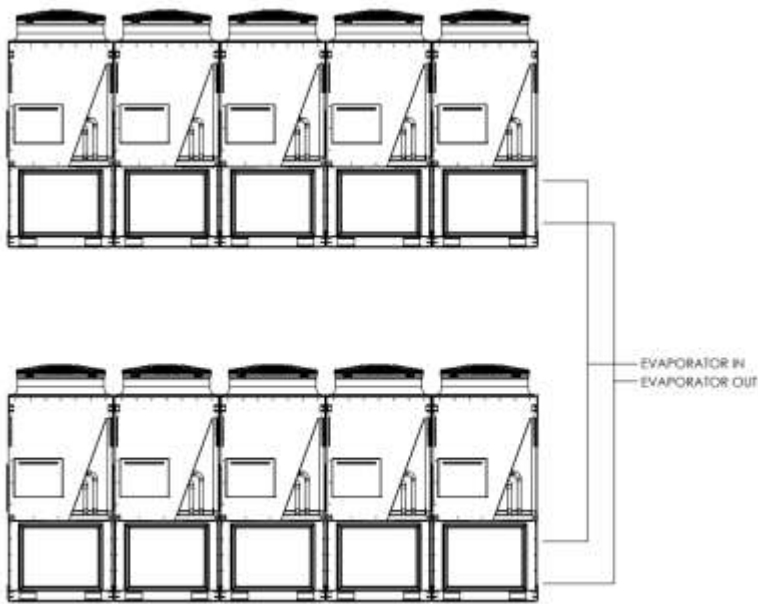

Figure 10 – Split Supply /Return Line

Nominal Capacity (tons)	Maximum number of units operating on COMMON supply / return line	Maximum number of units operating on SPLIT supply / return line*
10	10	10
15	10	10
20	10	10
30	10	10
40	10	10
50	8	10
60	6	10
70	5	10
80	5	10

Model Number Description

Digits 1 to 3— Model

ACC = Air-Cooled Chiller

Digit 4 — Chiller Type

S = Single Chiller

M = Modular Chiller in Array System

Digits 5 to 7 — Nominal Capacity

010 = 10 Tons

015 = 15 Tons

020 = 20 Tons

025 = 25 Tons

030 = 30 Tons

040 = 40 Tons

050 = 50 Tons

060 = 60 Tons

070 = 70 Tons

080 = 80 Tons

090 = 90 Tons

Digit 8 — Unit Voltage

A = 208 V/60 Hz/3 Phase

B = 230 V/60 Hz/3 Phase

F = 460 V/60 Hz/3 Phase

G = 575 V/60 Hz/3 Phase

Digits 9 — Unit Application

A = Air-Cooled Chiller

B = Air-Cooled Chiller (Low Ambient)

C = Air-Cooled Chiller (High Ambient)

D = Heat Pump

Digit 10 - Steps of Capacity

A = Single Circuit - On/Off Compressor

B = Single Circuit - Tandem Compressors

C = Single Circuit - Variable Speed Compressor

D = Circuit 1 - On/Off Compressor; Circuit 2 - On/Off

Compressor

E = Circuit 1 - Tandem Compressors; Circuit 2 - On/Off

Compressor

F = Circuit 1 - Tandem Compressors; Circuit 2 - Tandem

Compressors

G = Circuit 1 - Variable Speed; Circuit 2 - On/Off Compressor

H = Circuit 1 - Variable Speed; Circuit 2 - Tandem

Compressors

J = Circuit 1 - Variable Speed; Circuit 2 - Variable Speed

Digit 11 - Refrigerant Type

2 = R-454B

Digit 12 - Unit Efficiency

0 = Standard Efficiency

1 = High Efficiency

Digit 13 — Design Sequence

0 = Factory Assigned

Digit 14 - Evaporator Heat Exchanger Type

0 = Brazed Plate

1 = Shell and Tube

2 = High-Capacity Brazed Plate

Digit 15 — Evaporator Temp Range

0 = Standard Cooling 40 to 65°F [4.4 to 18.3°C]

1 = Standard Cooling/Ice Making 15 to 65°F [-9.4 to 18.3°C]

Digit 16 - Evaporator Valves

0 = No Valve

1 = Constant Flow Array - Manual Balancing/Isolating Valve

2 = Variable Flow Array - Motorized Isolating Valve

Digit 17 - Air-Cooled Condenser Heat Exchanger Type

0 = Microchannel Heat Exchanger (MCHE)

C = E-Coat Microchannel Heat Exchanger (MCHE)

Digit 18 - Condenser Fan Control

0 = Fixed Speed

1 = Variable Speed

Digit 19 - Condenser Water Heat Recovery

0 = No Heat Recovery

1 = Full Heat Recovery

Digit 20 — Heat Recovery Condenser Control Valves

0 = None (Two-pipe_

1 = Four-Pipe Heat Recovery

2 = Four-Pipe Heating/Cooling Optimized, Heat Pump

3 = Four-Pipe, Heat Recovery + Heating/Cooling Optimized Heat Pump

Digit 21 — Power Connection

0 = Terminal Block

A = Non-Fused Disconnect Switch

B = Fused Disconnect Switch

C = High SCCR Fuse Block

D = Distribution Panel for Array

Digit 22 - Power Feed

0 = 5 kA Rating

A = 5 kA Rating + Phase and Voltage Monitor

B = 100 kA Rating

C = 100 kA Rating + Phase and Voltage Monitor

Digit 23 - Service Options

0 = None

A = LED Lighted Control Cabinet

B = Factory Wired 115V Outlet

C = Field Wired 115V Outlet

D = LED Lighted Control Cabinet + Factory Wired 115V

Outlet

E = LED Lighted Control Cabinet + Field Wired 115V Outlet

Digit 24 - Control Style

0 = Non-Array, Single Unit Controller

A = Master Controller w/ Single Controller per Array

B = Supervisor Array Controller w/ Controller per Module

C = Secondary Expansion Board Module

Digit 25 — Local Unit Controller Interface

0 = Keypad with Dot Pixel Display

B = 15.4" Color Touchscreen

Digit 26 — Remote BMS Interface (Digital Comm)

0 = None

2 = Lon Talk®

4 = BACnet® MS/TP

5 = BACnet IP

6 = MODBUS®

Digit 27 - Blank

0 = Blank

Digit 28 - Refrigeration Options

0 = None

1 = Active Freeze Protection All Circuits

2 = Hot Gas Bypass All Circuits

Digit 29 - Refrigeration Accessories

0 = None

A = Compressor Isolation Valves

B = Replaceable Core Filter Driers

C = Replaceable Core Filter Driers + Compressor Isolation Valves

Digit 30 - Water Connection

0 = No Header Piping (Single Unit)

1 = Grooved Pipe Connection, Units Connected Side-to-Side

Digit 31 - Water Side Pressure

0 = 150 psi

A = 300 psi

Digit 32 - Water Strainer(s)

0 = None

A = Chilled Water Wye Strainer

B = Chilled Water Wye Strainer with installation kit

C = Heat Recovery Water Wye Strainer

D = Condenser Water Wye Strainer with installation kit

E = Chilled & Heat Recovery Water Wye Strainer

E = Chilled & Heat Recovery Water Wye Strainer

F = Chilled & Heat Recovery Water Wye Strainer with installation kit

Digit 33 - Water Accessories

0 = Chilled Water Flow Switch

Digit 34 - Free Cooling

0 = No Free Cooling Coil

1 = With Free Cooling Coil(s)

Digit 35 — Sound Attenuator

0 = None

A = Neoprene Pads

B = Compressor Sound Blanket(s)

C = Factory Sound Enclosure Cabinet(s)

D = Both sound blanket and enclosure

E = Compressor Sound Blanket(s) + Neoprene Pads

F = Factory Sound Enclosure Cabinet(s) + Neoprene Pads

G = Both sound blanket and enclosure + Neoprene Pads

Digit 36 - Guards

0 = None

A = Wire Mesh Coil Guards

B = Base + Coil Wire Mesh Guards

C = Coil Louvers

D = Base + Coil Louvers

Digit 37 - Exterior Finish & Shipping Splits

0 = Standard Paint, Each Module Packaged Separately

B = Custom Paint, Each Module Packaged Separately

Digit 38 - Warranty

0 = Standard Warranty

A = Five Year Compressor Only Parts Warranty (AC)

B = Factory Startup + Owner Training + Two Year Parts & Labor Warranty

C = Factory Startup + Owner Training + Three Year Parts & Labor Warranty

D = Factory Startup + Owner Training + Four Year Parts & Labor Warranty

E = Factory Startup + Owner Training + Five Year Parts & Labor Warranty

F = Factory Startup + Two Year Parts & Labor Warranty

G = Factory Startup + Three Year Parts & Labor Warranty

H = Factory Startup + Four Year Parts & Labor Warranty

J = Factory Startup + Five Year Parts & Labor Warranty

K = Factory Startup + First Year Labor Only Warranty

L = Factory Startup + Owner Training + First Year Labor Only Warranty

M = Factory Startup + Owner Training + Two Year Parts Only Warranty

N = Factory Startup + Owner Training + Three Year Parts Only Warranty

P = Factory Startup + Owner Training + Five Year Parts Only Warranty

Q = Factory Startup + Two Year Parts Only Warranty

R = Factory Startup + Three Year Parts Only Warranty

S = Factory Startup + Five Year Parts Only Warranty

T = Factory Startup + Five Year Compressor Only Parts Warranty (AC)

U = Factory Startup + Owner Training + Five Year Compressor Only Parts Warranty (AC)

V = Factory Startup Service + 1 Year Parts Only Warranty

W = Factory Startup Service w/Owner Training + 1 Year Parts Only Warranty

X = Two Year Parts Only Warranty

Y = Three Year Parts Only Warranty

Z = Five Year Parts Only Warranty

Digit 39 — Special Options

0 = None

X = With Specials

Digits 4 — Chiller Type

ACC chillers can be applied as both single and modular chillers.

S = Single Chiller - ACC chillers can be applied in standalone applications needing between 10 to 80 tons of cooling. In standalone applications, a single unit controller is selected in digit 24 and chiller headers are not required and the “no header” option can be selected in Digit 30.

M = Modular Chiller in Array System - More than one ACC modular chiller may be piped together (to form an array of chillers) for higher capacity and/or redundant chiller applications, an array controller package must be provided from the factory.

Digits 5 to 7 — Nominal Capacity

The first numbers of the model string designate nominal tons cooling. Actual capacities will vary with conditions.

010 = 10 Tons

015 = 15 Tons

020 = 20 Tons

025 = 25 Tons

030 = 30 Tons

040 = 40 Tons

050 = 50 Tons

060 = 60 Tons

070 = 70 Tons

080 = 80 Tons

090 = 90 Tons

**Note: The nominal capacities reflect the use of R-454B refrigerant and a standard heat exchanger*

Digit 8 — Unit Voltage

All units have single point power blocks with grounding lugs and 12V control circuits.

A = 208 V/60 Hz/3 Phase

B = 230 V/60 Hz/3 Phase

F = 460 V/60 Hz/3 Phase

G = 575 V/60 Hz/3 Phase

Digit 9 — Unit Application

A = Air-Cooled Chiller – Standard air-cooled chiller with optional shell and tube or brazed plate evaporator.

B = Air-Cooled Chiller (Low Ambient) – Air-Cooled chiller with special considerations for operation down to -20°F

C = Air-Cooled Chiller (High Ambient) – Air-Cooled chiller with high capacity condensers for operation up to 115°F

D = Heat Pump – Chiller can produce hot or chilled water via reversing valve in refrigeration system.

Digit 10 — Steps of Capacity

A = Single Circuit - On/Off Compressor – One fixed speed compressor on one refrigeration circuit

B = Single Circuit - Tandem Compressors– Two fixed speed compressors on one refrigeration circuit

C = Single Circuit - Variable Speed Compressor – One variable speed compressor on one refrigeration circuit

D = Circuit 1 - On/Off Compressor; Circuit 2 - On/Off Compressor – One fixed speed compressor on first refrigeration circuit; One fixed speed compressor on second refrigeration circuit

E = Circuit 1 - Tandem Compressors; Circuit 2 - On/Off Compressor – Two fixed speed compressors on first refrigeration circuit; One fixed speed compressor on second refrigeration circuit

F = Circuit 1 - Tandem Compressors; Circuit 2 - Tandem Compressors – Two fixed speed compressors on first refrigeration circuit; Two fixed speed compressors on second refrigeration circuit

G = Circuit 1 - Variable Speed; Circuit 2 - On/Off Compressor– One variable speed compressor on first refrigeration circuit; One fixed speed compressor on second refrigeration circuit

H = Circuit 1 - Variable Speed; Circuit 2 - Tandem Compressors– One variable speed compressor on first refrigeration circuit, Two fixed speed compressors on second refrigeration circuit

J = Circuit 1 - Variable Speed; Circuit 2 - Variable Speed - One variable speed compressor on first refrigeration circuit; One variable speed compressor on second refrigeration circuit

Digit 11 — Refrigerant Type

2 = R-454B

Digit 12 — Efficiency

1 = Standard Efficiency

2 = **High Efficiency** – Additional heat transfer surface area include to increase capacity and/or reduce power consumption

Digit 13 — Design Sequence

0 = Factory Assigned

Digit 14 — Evaporator Heat Exchanger Type

0 = Brazed Plate - Brazed plate heat exchangers are one of the most efficient ways to transfer heat. They are designed to provide unparalleled performance with the lowest life-cycle cost.

1 = Shell and Tube – Shell and tube heat exchanger with grooved water connection and 3/4” closed-cell rubberized insulation. (only available on single chillers)

2 = High Capacity Brazed Plate – Oversized brazed plate for 40°F leaving water applications.

3 = High Capacity Shell and Tube – Oversized shell and tube heat exchanger for glycol applications. (only available on single chillers)

6 = Remote Brazed Plate = Option 1 for remote field mounting

7 = Remote Shell and Tube = Option 2 for remote field mounting

8 = Remote High Capacity Brazed Plate = Option 3 for remote field mounting

9 = Remote High Capacity Shell and Tube = Option 4 for remote field mounting

Digit 15 — Evaporator Temperature Range

0 = Standard Cooling 40 to 65°F [4.4 to 18.3°C] – The chiller with *standard* evaporator must not be operated with a leaving water temperature of less than 42°F for a plain water application. The chiller with *high capacity* evaporator must not be operated with a leaving water temperature of less than 40°F for a plain water application.

1 = Standard Cooling/Ice Making 15 to 65°F [-6.7 to 18.3°C] - The dual roles of an ice-making chiller can substantially reduce the installed cost of the system. An ice-making chiller is NOT a conventional chiller with two different leaving-fluid temperature setpoints. An ice-making chiller operates at maximum capacity when in ice-making mode. It continues to operate at maximum capacity until the leaving-fluid temperature reaches the target setpoint. At a 10°F delta across the evaporator, this limit indicates that all of the water inside the ice storage tanks has been frozen. An external signal can be sent to the chiller to reset the chilled water setpoint back to conventional chilled water leaving fluid temperature and the chiller will return to traditional chiller operation.

Digit 16 — Evaporator Flow and Valves

0 = Standalone Unit – No Valves

1 = Constant Flow Array / Manual Balancing Isolating Valve - For a proper hydronic balance in a constant flow system, manual balancing valves are factory installed in array headers. These valves can also be used to isolate a module in an array for service or cleaning. Constant flow pumping systems utilize a staged cooling system and a constant flow water pumping system. No modules are isolated at part load. Flow from “off” chillers mixes with the flow from active chillers in creating the leaving array temperature. The load may not be less than 25% of the full load in constant flow applications.

2 = Variable Flow Primary / Motorized Isolating Valve - Variable flow systems isolate modules not needed to meet current cooling or heating capacity by isolating modules with a factory installed motorized on-off valve. Variable flow systems utilize compressor staging and motorized isolation valves with a variable flow water pumping system to modulate cooling and water flow to meet chilled water needs and save operating energy costs. Cooling capacity is modulated by staging compressors and isolating modules based on the desired leaving water temperature. Water flow control is field provided and is usually modulated with VFD controlled variable flow primary pumps based on the differential pressure across the water system. The rate of change in flow rate must not exceed 10% of design flow gpm per minute.

Digit 17 — Condenser Heat Exchanger Type

0 = Microchannel Heat Exchanger (MCHE) – Aluminum coil with aluminum fins

C = E-Coat Microchannel Heat Exchanger (MCHE) – Polymer e-coating applied to the condenser coils. Coating surpasses a 6000-hour salt spray test per ASTM B117-90, yet is only 0.8-1.2 mils this and has excellent flexibility. Option is intended for use in coastal saltwater conditions under the stress of heat, salt, sand and wind and is applicable to all corrosive environments where a polymer coating is acceptable.

Digit 18 — Condenser Fan Control

0 = Fixed Speed – Air-cooled units can operate down to 35°F by cycling condenser fans.

1 = Variable Speed – Air-cooled units can operate down to 0°F by slowing or stopping condenser fans.

Digit 19 — Condenser Heat Recovery

0 = No Heat Recovery – Chiller operates to maintain chilled water temperature. No secondary condenser heat exchanger is installed.

1 = Heat Recovery – A full capacity brazed plate condenser is provided. Instead of rejecting heat to the air-cooled condenser, heat is recovered from the brazed plate heat exchanger and condenser water and can be used in many commercial facilities for preheating incoming air, reheat in dehumidification applications, washing, showering, and other everyday usage. Such facilities include:

- Office Buildings: reheat coils, boiler preheat, general usage
- Hospitals, laundry, showers, and sterilization (often separate from other systems)
- Dormitories: laundry, showers, and general usage
- Hotels: laundry, showers, pool heat, and general usage

All of these facilities require large quantities of makeup water that must be heated.

Digit 20 — Condenser Heat Recover Control Valves

0 = None

1= Four-Pipe Heat Recovery

2= Four-Pipe Heating/Cooling Optimized, Heat Pump

3= Four-Pipe, Heat Recovery + Heating/Cooling Optimized Heat Pump

Digit 21 — Power Connection

0 = Terminal Block - Terminal Block to land incoming power wiring.

A = Non-Fused Disconnect Switch - Non-fusible disconnect switches do not incorporate fuses into their enclosure and provide no circuit protection capability. The purpose of a non-fusible safety switch is to provide an easy means to open and close a circuit.

B = Fused Disconnect Switch - Fusible disconnect switches combine fuses with the switch in a single enclosure, providing an easy means to manually open and close the circuit while the fuses protect against overcurrent.

C = High SCCR Fuse Block - Short-circuit current ratings provide the level of fault current that a component or piece of equipment can safely withstand (based on a fire and shock hazard external to the enclosure). A 100kA SCCR can have significant impact in meeting safety and insurance requirements.

D = Distribution Panel Connection = Terminal Block; Module Power Connection = Circuit Breaker – This feature is used for the single point power options in Digit 25. Factory provided panelboard serves as a power distribution panelboard for chiller array.

Digit 22 — Power Feed

D = Power Feed to Each Unit (5 kA Rating) – Power is field provided to each chiller module in the array. This is beneficial in applications where redundancy or dual point power is desirable or to allow for smaller electrical feeds instead of a large single electrical feed.

A = Power Feed to Each Unit (5 kA Rating) + Phase and Voltage Monitor - This option includes field provided power and an additional factory-installed phase/power monitor designed to protect the chiller from premature failure and damage due to common voltage faults such as voltage unbalance, over/under voltage, phase loss, reversal, incorrect sequencing and rapid short cycling.

B = Power Feed to Each Unit (100 kA Rating) - Short-circuit current ratings provide the level of fault current that a component or piece of equipment can safely withstand (based on a fire and shock hazard external to the enclosure). A 100kA SCCR can have significant impact in meeting safety and insurance requirements.

C = Power Feed to Each Unit (100 kA Rating) + Phase and Voltage Monitor - This option includes field provided power and an additional factory-installed phase/power monitor designed to protect the chiller from premature failure and damage due to common voltage faults such as voltage unbalance, over/under voltage, phase loss, reversal, incorrect sequencing and rapid short cycling.

Digit 23 — Service Options

0 = None

A = LED Lighted Control Cabinet - LED lights provide bright lighting inside enclosure offer with long service life and can provide improve safety and visibility when service inside the enclosure is needed.

B = Factory Wired 115V Outlet – Factory wired electrical box with ground fault interrupter receptacle located within the control panel. The circuit is rated at 10 amps maximum and is factory wired to a step-down transformer and fuse block. The circuit is wired to the line side of the unit power block or power switch permitting use of the outlet while power to the unit is shut off.

Caution: When the power to the unit is disconnected with the factory installed unit power switch, the convenience outlet will remain live.

C = Field Wired 115V Outlet – Field wired electrical box with ground fault interrupter receptacle, located with the control panel. Receptacle is rated for 20 amps. The outlet must be field wired to a 115 VAC power supply.

D = LED Lighted Control Cabinet + Factory Wired 115V Outlet

E = LED Lighted Control Cabinet + Field Wired 115V Outlet

Digit 24 — Control Style

0 = Non-Array, Single Unit Controller – Standalone Controller has control board with twelve 0-5vdc sensor inputs, four 5vdc digital inputs, ten 230vac 6.3amp relay outputs, four 0-10vdc analog outputs, keypad, 128 x 64 dot pixel STN monochrome graphics LCD with 2.8" diagonal viewing area, real time clock, MCS-I/O, RS-232, RS-485 and Ethernet communication ports.

A = Master Secondary Controller w/ Single Controller per Array - This option allows up to six (6) ACC modular chillers to be controlled and operated. The Master-Secondary Array Controller requires only a single controller for the array. This option is beneficial in replacement applications where a single larger chiller, with one controller, is replaced by modular chillers controlled with one controller.

B = Supervisory Array Controller w/ Controller per Module - This option allows up to ten (10) ACC modular chillers to be controlled and operated. The Supervisory Array Controller requires each module have an individual unit controller. This option is beneficial in applications requiring seven (7) or more modules to be controlled and in applications where chiller uptime is critical. If communication between the individual ACC modular chiller unit controller(s) and the Supervisory Array Controller is lost, or the Supervisory Array Controller fails, the individual ACC modular chillers can be shifted into manual mode to operate independent from the Supervisory Array Controller and will maintain a “manual mode” default chilled leaving water temperature set point.

C = Secondary/Expansion Board – Secondary modules in the array have expansion boards to communicate inputs from the given module to the Master controller. The Master-Secondary Array Controller requires only a single controller for the array. This option is beneficial in replacement applications where a single larger chiller, with one controller, is replaced by modular chillers controlled with one controller.

Digit 25 — Local Unit Controller Interface

0 = Keypad with Dot Pixel Display - keypad, 128 x 64 dot pixel STN monochrome graphics LCD with 2.8" diagonal viewing area

B = 15.4-in. Color Touchscreen - Information and graphics are shown on high resolution (1280x800) LCD display with LED back lighting. The high-resolution screen makes it easy for the user to manage complex installations without losing the overall view or requiring a separate laptop. Pages can be navigated in a fast and straightforward manner.

Digit 26 — Remote BMS Interface (Digital Comm)

0 = None

2 = Lon Talk®

4 = BACnet® MS/TP

5 = BACnet® IP

6 = MODBUS®

Digit 27 — Blank

0 = Blank

Digit 28 — Refrigeration Options

0 = None

1 = Active Freeze Protection (All Circuits) – Active freeze protection is a suction pressure-based freeze protection. Active Freeze Protection is standard on all ACC Series chillers. The chiller's unit controller continually monitors the saturated suction pressure and will open (energize) the Active Freeze Protection solenoid if the suction pressure falls to approximately 101 psig (32°F). The solenoid closes (de-energizes) when the pressure climbs to approximately 105 psig (34°F) and the freezing potential no longer exists.

2 = Hot Gas Bypass (All Circuits) - Hot gas bypass can stabilize the system balance point by diverting hot, high- pressure refrigerant vapor from the discharge line directly to the low-pressure side of the system. This tactic keeps the compressor more fully loaded while the evaporator satisfies the part-load condition. The Jetson Active Freeze Protection can be configured to function as Hot Gas Bypass by configuring the controller to monitor both the leaving water temperature and the suction temperature. In Hot Gas Bypass operating mode, the Active Freeze Protection provides an additional step of capacity.

Digit 29 — Refrigeration Accessories

0 = Moisture Indicating Sight Glass - The sight glass shows if the liquid line has a full line of liquid or if it has bubbles which shows it's a liquid/vapor mix. It should not be used to determine proper charge. The moisture indicator shows if the system is dry or if it has harmful moisture content.

A = Moisture Indicating Sight Glass + Compressor Isolation Valves – In addition to the Moisture Indicating Sight Glass, ball type Compressor Isolation Valves are mounted on the cooling circuit discharge and liquid lines permitting isolation of the compressors and filter driers for service or replacement. The valves are located close to the compressors. The valve works through a quarter turn from open to closed. Teflon seals and gaskets are used with a nylon cap gasket to prevent accidental loss. This option reduces the amount of refrigerant that must be recovered during compressor service or replacement.

B = Moisture Indicating Sight Glass + Replaceable Core Filter Driers - In addition to the Moisture Indicating Sight Glass, Replaceable Core Filter Driers allow for easy changeout of the filter-drier element.

C = Moisture Indicating Sight Glass + Replaceable Core Filter Driers + Compressor Isolation Valves

Digit 30 — Water Connection

0 = No Header Piping (Heat Exchangers Only) used in single chiller applications

1 = Grooved Pipe Connection, Units Connected Side-to-Side – Chillers are set alongside other chillers along the long dimension. A common header is connected between chillers on the short dimension.



Digit 31 — Water Side Pressure

0 = 150 psi

A = 300 psi

Digit 32 — Water Strainer(s)

0 = None

A = Chilled Water Flow Wye Strainer – Factory provided, field installed wye strainer can be placed in a horizontal or vertical pipeline as long as the screen is in a downward position. Straining is accomplished via a 20-mesh lined straining element.

B = Chilled Water Wye Strainer with Installation Kit - Wye strainer installation kits provide piping transitions need to easily attach the wye strainer to the chiller.

C = Heat Recovery Water Flow Wye Strainer – Factory provided, field installed wye strainer can be placed in a horizontal or vertical pipeline as long as the screen is in a downward position. Straining is accomplished via a 20-mesh lined straining element.

D = Heat Recovery Water Wye Strainer with Installation Kit - Wye strainer installation kits provide the piping transitions needed to easily attach the wye strainer to the chiller.

E = Chilled and Heat Recovery Water Nominal Flow Wye Strainer

F = Chilled and Heat Recovery Water Wye Strainer with Installation Kit

Digit 33 — Water Accessories

0 = Chilled Water Flow Switch - An evaporator flow-proving device is required for all ACC Series chiller applications. A paddle style liquid flow switch is available with a NEMA Type 4X enclosure for field-installation.

Digit 34 — Free Cooling

0 = None

1 = With Free Cooling - Free cooling is an economical method of using low external air temperatures to assist in chilling water. When outdoor temperatures are lower relative to indoor temperatures, this system utilizes the cool outdoor air as a free cooling source.

Digit 35 — Sound Attenuator

0 = None

A = Neoprene Pads - In applications that are sensitive to noise and vibration, optional neoprene isolator pads can be provided for load bearing points on ACC chillers.

B = Compressor Sound Blankets - Factory installed Compressor Sound Blankets provide insulated sound covers on each compressor. These blankets dampen compressor generated sound. The blankets can be used alone or in combination with a sound cabinet.

C = Factory Sound Enclosure Cabinet - The sound enclosure is a factory installed option. The panels completely encase the chiller module. The panels, lined with sound absorbing insulation, can be removed for access in case of service and provide a streamlined appearance to the product while in place.

D = Compressor Sound Blankets + Factory Sound Enclosure Cabinet

E = Compressor Sound Blanket(s) + Neoprene Pads

F = Factory Sound Enclosure Cabinet(s) + Neoprene Pads

G = Compressor Sound Blankets + Factory Sound Enclosure Cabinet + Neoprene Pads

Digit 36 — Guards

0 = None

A = Wire Mesh Coil Guards - Optional factory-installed, vinyl-coated, welded-wire guards provide protection for the condenser coils.

B = Base + Coil Wire Mesh Guards - Optional factory-installed, vinyl-coated, welded-wire guards provide protection for the condenser coils and lower portion of the unit.

B = Coil Louvers - Optional factory-installed, louvered panels provide protection for the condenser coils.

C = Base + Coil Louvers - Optional factory-installed, louvered panels provide protection for the condenser coils and lower portion of the unit.

Digit 37 — Exterior Finish and Shipping Splits

0 = Standard Paint, Each Module Packaged Separately – Standard Jetson paint process uses primer wash then spray coated with a two-part polyurethane exterior paint.

B = Custom Paint, Each Module Packaged Separately – Custom colors are available for applications requiring ACC Series chiller to match existing color palettes.

Digit 38 — Warranty

0 = Standard Warranty – Warranty period is a period of twelve (12) months from date of start-up or eighteen (18) months from date of original shipment, whichever may occur first.

A = Five Year Compressor Only Parts Warranty - Additional parts only warranty covering compressor(s) through sixty (60) months from date of shipment.

B= Factory Startup + Owner Training + Two Year Parts & Labor Warranty - Pre-startup unit inspection, startup, and immediate part repair/replacement at the time of startup (if needed) by Modine Service Technicians. Parts and labor warranty period is twenty-four (24) months from date of startup or thirty (30) months from date of original shipment, whichever may occur first. Training includes standard operation and routine maintenance instruction.

C= Factory Startup + Owner Training + Three Year Parts & Labor Warranty - Pre-startup unit inspection, startup, and immediate part repair/replacement at the time of startup (if needed) by Modine Service Technicians. Parts and labor warranty period is thirty-six (36) months from date of startup or forty-two (42) months from date of original shipment, whichever may occur first. Training includes standard operation and routine maintenance instruction.

D= Factory Startup + Owner Training + Four Year Parts & Labor Warranty - Pre-startup unit inspection, startup, and immediate part repair/replacement at the time of startup (if needed) by Modine Service Technicians. Parts and labor warranty period is forty-eight (48) months from date of startup or fifty-four (54) months from date of original shipment, whichever may occur first. Training includes standard operation and routine maintenance instruction.

E= Factory Startup + Owner Training + Five Year Parts & Labor Warranty - Pre-startup unit inspection, startup, and immediate part repair/replacement at the time of startup (if needed) by Modine Service Technicians. Parts and labor warranty period is sixty (60) months from date of startup or sixty-six (66) months from date of original shipment, whichever may occur first. Training includes standard operation and routine maintenance instruction.

F= Factory Startup + Two Year Parts & Labor Warranty - Pre-startup unit inspection, startup, and immediate part repair/replacement at the time of startup (if needed) by Modine Service Technicians. Parts and labor warranty period is twenty-four (24) months from date of startup or thirty (30) months from date of original shipment, whichever may occur first.

G= Factory Startup + Three Year Parts & Labor Warranty - Pre-startup unit inspection, startup, and immediate part repair/replacement at the time of startup (if needed) by Modine Service Technicians. Parts and labor warranty period is thirty-six (36) months from date of startup or forty-two (42) months from date of original shipment, whichever may occur first.

H= Factory Startup + Four Year Parts & Labor Warranty- Pre-startup unit inspection, startup, and immediate part repair/replacement at the time of startup (if needed) by Modine Service Technicians. Parts and labor warranty period is forty-eight (48) months from date of startup or fifty-four (54) months from date of original shipment, whichever may occur first.

J= Factory Startup + Five Year Parts & Labor Warranty - Pre-startup unit inspection, startup, and immediate part repair/replacement at the time of startup (if needed) by Modine Service Technicians. Parts and labor warranty period is sixty (60) months from date of startup or sixty-six (66) months from date of original shipment, whichever may occur first.

K= Factory Startup + First Year Labor Only Warranty - Pre-startup unit inspection, startup, and immediate part repair/replacement at the time of startup (if needed) by Modine Service Technicians. Parts and labor warranty period is twelve (12) months from date of startup or eighteen (18) months from date of original shipment, whichever may occur first.

L= Factory Startup + Owner Training + First Year Labor Only Warranty - Pre-startup unit inspection, startup, and immediate part repair/replacement at the time of startup (if needed) by Modine Service Technicians. Parts and labor warranty period is twelve (12) months from date of startup or eighteen (18) months from date of original shipment, whichever may occur first. Training includes standard operation and routine maintenance instruction.

M= Factory Startup + Owner Training + Two Year Parts Only Warranty - Pre-startup unit inspection, startup, and immediate part repair/replacement at the time of startup (if needed) by Modine Service Technicians. Parts warranty period is twenty-four (24) months from date of startup or thirty (30) months from date of original shipment, whichever may occur first. Training includes standard operation and routine maintenance instruction.

N= Factory Startup + Owner Training + Three Year Parts Only Warranty - Pre-startup unit inspection, startup, and immediate part repair/replacement at the time of startup (if needed) by Modine Service Technicians. Parts warranty period is thirty-six (36) months from date of startup or forty-two (42) months from date of original shipment, whichever may occur first. Training includes standard operation and routine maintenance instruction.

P= Factory Startup + Owner Training + Five Year Parts Only Warranty - Pre-startup unit inspection, startup, and immediate part repair/replacement at the time of startup (if needed) by Modine Service Technicians. Parts warranty period is sixty (60) months from date of startup or sixty-six (66) months from date of original shipment, whichever may occur first. Training includes standard operation and routine maintenance instruction.

Q= Factory Startup + Two Year Parts Only Warranty - Pre-startup unit inspection, startup, and immediate part repair/replacement at the time of startup (if needed) by Modine Service Technicians. Parts warranty period is twenty-four (24) months from date of startup or thirty (30) months from date of original shipment, whichever may occur first.

R= Factory Startup + Three Year Parts Only Warranty - Pre-startup unit inspection, startup, and immediate part repair/replacement at the time of startup (if needed) by Modine Service Technicians. Parts warranty period is thirty-six (36) months from date of startup or forty-two (42) months from date of original shipment, whichever may occur first.

S= Factory Startup + Five Year Parts Only Warranty - Pre-startup unit inspection, startup, and immediate part repair/replacement at the time of startup (if needed) by Modine Service Technicians. Parts warranty period is sixty (60) months from date of startup or sixty-six (66) months from date of original shipment, whichever may occur first.

T= Factory Startup + Five Year Compressor Only Parts Warranty (AC) - Pre-startup unit inspection, startup, and immediate part repair/replacement at the time of startup (if needed) by Modine Service Technicians. Additional parts only warranty covering compressor(s) through sixty (60) months from date of shipment.

U= Factory Startup + Owner Training + Five Year Compressor Only Parts Warranty (AC) - Pre-startup unit inspection, startup, and immediate part repair/replacement at the time of startup (if

needed) by Modine Service Technicians. Additional parts only warranty covering compressor(s) through sixty (60) months from date of shipment. Training includes standard operation and routine maintenance instruction.

V= Factory Startup Service + 1 Year Parts Only Warranty - Pre-startup unit inspection, startup, and immediate part repair/replacement at the time of startup (if needed) by Modine Service Technicians. All parts warranty period is twelve (12) months from date of startup or eighteen (18) months from date of original shipment, whichever may occur first.

W= Factory Startup Service w/Owner Training + 1 Year Parts Only Warranty - Pre-startup unit inspection, startup, and immediate part repair/replacement at the time of startup (if needed) by Modine Service Technicians. All parts warranty period is twelve (12) months from date of startup or eighteen (18) months from date of original shipment, whichever may occur first. Training includes standard operation and routine maintenance instruction. Training includes standard operation and routine maintenance instruction.

X= Two Year Parts Only Warranty - Additional parts only warranty covering all parts through twenty-four (24) months from date of shipment.

Y= Three Year Parts Only Warranty - Additional parts only warranty covering all parts through thirty-six (36) months from date of shipment.

Z= Five Year Parts Only Warranty - Additional parts only warranty covering all parts through sixty (60) months from date of shipment.

Digit 39 — Special Options

0 = None

X = With Specials

LITERATURE CHANGE HISTORY

10/07/20 – New

10/19/20 – Updated drawings

10/27/20 – Updated general data for min/max flow

10/11/21 – Updated figures 10-15 with new control box orientation. Removed digit 30 = 2: end-to-end option.

12/06/21 – Expanded variable flow text

12/15/21 – Updated page numbers in model description section

01/03/22 – Updated digit 29 isolation valve description to move second valve from suction line to liquid line.

12/07/22 – Updated unit shipping weight table

02/28/23 – Reduced maximum operating ambient from 125F to 115F. Updated unit clearance text.

01/09/24 – Updated digits 5,6,7,9,20 and 38.

THIS PAGE INTENTIONALLY BLANK

THIS PAGE INTENTIONALLY BLANK



**905 W. Cotton Street
Longview, TX 75604
Phone: 903-758-2900
www.JetsonHVAC.com**

**Product Catalog ACC Series
Revision 250926**

Factory Technical Support: 903-758-2900

Note: Before calling Technical Support, please have the model and serial number of the unit available.

Parts: For replacement parts, please contact your local Jetson Representative.

It is the intent of Jetson to provide accurate and current product information. However, in the interest of product improvement, Jetson reserves the right to change pricing, specifications, and/or design of its product without notice, obligation, or liability.

Copyright © Jetson, all rights reserved throughout the world.