

FWCD Series Chillers

Product Catalog



Jetson
by **MODINE**[®]

JET17-101

Contents

Features and Benefits	5
Smart Controls	7
Application Information.....	11
Line Sizing Guidelines.....	18
Digits 5 to 7 — Nominal Capacity	24
Digit 8 — Unit Voltage.....	24
Digit 9 — Unit Application	24
Digit 10 — Refrigerant Style.....	24
Digit 11 — Number of Circuits	24
Digit 12 — Efficiency/Capacity	25
Digit 13 — Design Sequence.....	25
Digit 14 — Array System	25
Digit 15 — Evaporator Heat Exchanger Type.....	25
Digit 16 — Evaporator Fluid Type.....	25
Digit 17 — Evaporator Flow	25
Digit 18 — Evaporator Temperature Range.....	26
Digit 19 — Evaporator Control Valves	26
Digit 20 — Condenser Heat Exchanger Type	26
Digit 21— Condenser Fluid Type.....	26
Digit 22 — Condenser Heat Recovery	26
Digit 23 — Condenser Corrosion Resistance	27
Digit 24 — Condenser Control Valves.....	27
Digit 25 — Power Feed	27
Digit 26 — Power Connection.....	28
Digit 27 — Service Options.....	28
Digit 28 — Panel Ampere Rating.....	29
Digit 29 — Control Style.....	29
Digit 30 — Local Unit Controller Interface	29
Digit 31 — Remote BMS Interface (Digital Comm).....	30
General Data	37
Pressure Drop Curves	38
Electrical Service Sizing Data	41
Array Single Point Power Distribution Panel Size	42

Weights and Dimensions 43
Literature Change History..... 50

Features and Benefits

Flexibility of Design

With model sizes ranging from 20 to 85 tons and configurable into arrays up to 600 tons the FWCD Series chiller can suit any job. The installation of small chillers as needed is both more economically practical and energy efficient than a single large centralized chilled water plant, especially at part load and in application where chiller uptime and redundancy are important. For new installations or building renovations, the FWCD Series easily allows large tonnage systems to be built with multiple smaller modules.

FWCD Series chillers are specifically scaled to fit through a standard 36" doorway and to fit onto a standard elevator, ensuring fast and easy delivery and installation. Because the FWCD Series can be applied as an individual chiller or applied as a high-capacity multi-stage, multi-chiller array by using the optional array controller package, the FWCD Series chillers can be configured to meet capacity needs ranging from 20 tons to 600 tons.

Convenience

The FWCD Series chiller was designed with convenient installation and servicing in mind. The FWCD Series chiller is delivered to the jobsite ready for installation and startup. Jetson offers a wide variety of standard and optional features, including single or dual circuit refrigeration systems and shell and tube or brazed plate condensers. All of these components are piped, wired, and run tested before they are shipped from the factory. All models feature lockable, hinged access doors to the electrical components. Water connections are conveniently located in the back of the unit to minimize the equipment's installed footprint and provide clear access to heat exchangers, filter driers and thermal expansions valves at the front of the unit. Every FWCD Series modular chiller has a detachable water header section consisting of

left-hand or right-hand chilled water or condenser water customer connections. Customer connections are 6-inch grooved pipe and arrive ready for immediate connection to the customer supply/return lines and, if applicable, to other adjacent FWCD Series modular chillers.

Reliability

The active freeze protection system on FWCD chillers continuously monitors the suction temperature to prevent evaporator operation in freezing conditions. When suction pressure approaches freezing conditions the active freeze protection reacts to warm the evaporator. If the active freeze protection system can prevent a freezing condition the chiller will continue normal operation. If a freeze condition is imminent, the machine will lock out and provide an alarm. This system helps enhance the longevity of chiller operation and is included on all Jetson water-cooled chillers. Core temperature sensors are installed in every FWCD brazed-plate evaporator as a redundant low water temperature safety.

Jetson integrates the latest in scroll compressor technology into all of its products for improved operational reliability. Each chiller is factory inspected and checked for leaks before leaving the factory. Current transducer continuously monitors compressor amp draw and stop operation if excessive amps occur.

Every FWCD modular chiller is run tested at full load conditions before shipment, minimizing startup delay. A data log is retained at the factory for each unit shipped.

Quiet Operation

In addition to being dependable, the hermetic scroll compressors included in each FWCD Series chiller offer quieter operation than comparable reciprocating compressors. Each compressor is placed on rubber isolator to minimize vibration. FWCD Series chillers are available with compressor blankets and/or a sound enclosure. Sound enclosures fully enclose the compressors with sound dampening material to provide enhanced sound reduction compared to sound blankets or non-isolated compressors.

Efficiency

The use of scroll compressors, while being both reliable and quiet, also boasts reduced frictional losses and improved efficiency over comparable reciprocating compressors. The FWCD Series chiller maintains control on the leaving water temperature by cycling compressors on and off at part load conditions, maintaining efficient operation across the entire range of operation. All FWCD Series chillers meet or exceed ASHRAE 90.1 – 2022.

Serviceability

Standard, integral valving makes it possible to isolate the FWCD heat exchangers for routine maintenance. Once isolated, both heat exchangers have inlet and outlet grooved pipe connections readily accessible to allow for backflushing, chemical cleaning and/or rodding of the shell-and-tube condenser without having to remove the exchanger. If a heat exchanger must be removed and replaced, all necessary work can be performed at the front of the chiller without having to remove other unrelated parts.

Smart Controls

Every model is furnished with a microprocessor controller that cycles the compressors to maintain the leaving water temperature over a wide range of operating conditions. A convenient alphanumeric LCD display that is updated once per second. Inputs are made using large function keys with menu driven prompts. Schedules are available with a seven-day built-in time clock. Terminals are provided for remote stop-start and for remote reset of the leaving water temperature setpoint. The controller features 12 analog and 4 digital inputs as well as 4 analog outputs. Nonvolatile memory is used for all control functions. Additional optional features include diagnostic sensors for pressure and temperature on each refrigerant circuit, current sensors for each compressor, and a RS-485 port allowing communication with other manufacturer's control systems.



Figure 1 -Keypad Controller Display

Building Communications

When the FWCD Series chiller is used in conjunction with a building management system (BMS), the chiller can be monitored and given input from a remote location. The chiller can be set up to fit into the overall building control strategy by using remote run/stop input, remote

demand limit reset and/or remote chilled water reset functions.

BACnet® IP , Modbus™ TCP/IP (Modbus RTU uses the RS485 network port), BACnet® MS/TP, Johnson N2 and LonTalk® are optional protocols that can be factory-installed. The unit controller can facilitate hundreds of control points, including the following popular BMS communications:

- Remote Off/Auto signal (input from BMS)
- Demand Limit Reset signal (input from BMS)
- Chilled Water Temperature Reset signal (input from BMS)
- Customer Alarm relay (view only)
- Chiller Run Indication (view only)
- Entering Chilled Water Temperature (view only)
- Leaving Chilled Water Temperature (view only)
- Chilled Water Flow Switch input (view only)
- Condenser Pump relay (view only)
- Chilled Water Pump relay (view only)

System Protection

A complete safety lockout system with alarms protects the FWCD Series chiller operation to potentially avoid compressor and evaporator failures. The unit controller directly senses pressures, temperatures, amperage, motor faults, etc. All control variables that govern the operation of the chiller are evaluated every second for exact control and protection. The following is an abbreviated list of safeties that are incorporated into the standard chiller algorithm control.

- **No Flow Protection** – To protect the chiller from no water flow to the evaporator, the chiller is enabled to run only if the required flow proving device indicates there is flow present. If the chiller is active and flow is lost; the chiller will lock out and an alarm is generated.
- **Low Suction Pressure** – To protect the compressors and evaporator, if the refrigerant

suction pressure drops below the set point value for a specified period of time, a safety trip occurs. This safety is bypassed when the compressor is in a Pump Down state.

- **Unsafe Suction Pressure** – To protect the compressors and evaporator, if the refrigerant suction pressure drops below the set point value for a specified period of time, the chiller will immediately lock out, and an alarm is generated.
- **Heat Exchanger Freeze Protection** – To protect the evaporator from low water temperatures, the chilled water temperature is monitored inside the core of the evaporator and leaving the evaporator. If these temperatures fall below their set point temperatures for the set period of time, the entire system will lock out and an alarm is generated.
- **Active Freeze Protection System** – Working in conjunction with the low suction pressure and freeze protection safeties to avoid nuisance safety trips, the active freeze protection valve is opened when the suction pressure goes below the lower set point value and warms the evaporator until the freeze conditions are abated. The valve will stay open until the suction pressure rises safely above the upper set point level.
- **High and Low Discharge Pressure, High and Low Superheat, High and Low Compressor Amps** – The compressors will be locked out if any one of these control variables rises above the upper set point value or falls below the lower set point value for the set amount of time for each, and an alarm is generated.
- **Optional Phase/Power Monitor** – The factory-installed phase/power monitor continuously monitors the incoming power supply to the chiller for low voltage, phase rotation reversal, loss of phase and phase imbalance. Should one of these parameters be incorrect, the phase/power monitor relay will lock out (de-energize) and the fault LED on the monitor will blink. The unit

controller will indicate the lockout, and an alarm is generated.

As an additional layer of system protection, mechanical high- and low-pressure switches are used in conjunction with the refrigerant circuit high- and low-pressure transducers and unit controller.

Standard Peripheral Control Features

The following peripheral control features and program logic come standard on all FWCD Series chillers. Designated terminals on the field connection terminal strip in the control panel are provided for field connection of:

- **Remote Off/Auto** (dry contact closure from a remote device - input)
- **Required Chilled Water Flow Proving Device** (dry contact closure from a remote device - input)
- **Remote Alarm** (dry contact closure to a remote device - output)
- **Required Chilled Water Pump Enable** (dry contact closure for 1 chilled water pump - output)
- **Condenser Water Pump Enable** (dry contact closure for 1 condenser water pump - output)

Standard Capacity Control

Standard capacity control on the FWCD Series chillers is accomplished by staging the scroll compressors on and off. The unit controller will maintain a set point leaving chilled water temperature within a control zone using proportional, integral derivative (PID) logic. If the leaving chilled water temperature starts to decrease and falls below the set point, the unit controller will turn one stage off. A further reduction in temperature will result in a second stage being turned off. The reverse is true as the leaving chilled water temperature increases. Lead/lag logic is used to even the run time on the individual compressors.

Optional Capacity Control

Chilled water temperature reset can be accomplished in two ways. In buildings with a building management system, the FWCD Series unit controller allows the BMS to communicate an offset to the chilled water temperature set point. If a BMS is not being used, the unit controller can accept a field provided 0 to 5 VDC analog input signal. As the input voltage varies away from center (2.5V), the chilled water temperature set point will be offset proportionally.

Note: This control logic is factory-installed and must be denoted at the time of ordering.

Demand limiting is a form of capacity control that limits the number of capacity steps the compact chiller is allowed to operate. It can be accomplished in the same two ways as the chilled water temperature reset: through BMS or field-provided 0 to 5 VDC input signal.

Note: This control logic is factory-installed and must be denoted at the time of ordering.

Array Control

The array controller option allows the FWCD Series chiller to be an ideal solution for facilities with growing occupancy and structural

expansion plans because chillers can be added as capacity needs increase or applications where convenient redundancy is needed.

FWCD Series water-cooled chiller arrays can be controlled by two different array controller configurations, depending on the needs of the application. Both options allow the array to be controlled and operated like a single, higher capacity, multistage chiller. Capacity modulation and equalization of compressor run time is managed by the array controller. The array controller uses the same standard capacity control logic as an individual FWCD unit controller but with more stages of capacity.

Supervisory Array Controller

This option allows up to ten (10) FWCD Series chillers to be controlled and operated. The Supervisory Array Controller requires each module have an individual unit controller. This option is beneficial in applications requiring seven (7) or more modules to be controlled and in applications where chiller uptime is critical.

Power (115VAC) must be provided to a circuit breaker inside the Supervisory Array Controller enclosure panel to power the Supervisory Array Controller. The Supervisory Array Controller enclosure also contains a field connection terminal strip and door-mounted off/auto switch, run indicator light and alarm indicator light.

The Supervisory Array Controller is accessed in the same manner as the unit controller, through the keypad display or PC/laptop. If communication between the individual FWCD Series chiller unit controller(s) and the Supervisory Array Controller is lost, or the Supervisory Array Controller fails, the individual FWCD Series chillers can be shifted into manual mode to operate independent from the Supervisory Array Controller and will maintain a “manual mode” default chilled leaving water temperature set point.

N+1 logic can be utilized with the Supervisory Array Controller when each chiller in an array is equipped with optional chilled water motorized on-off valve, optional condenser water regulating valve and a standby chiller is installed in the array.



Figure 2 - Supervisor Controller Layout

Master-Secondary Array Controller

This option allows up to six (6) FWCD Series chillers to be controlled and operated. The Master-Secondary Array Controller requires only a single controller for the array. This option is beneficial in replacement applications where a single larger chiller, with one controller, is replaced by modular chillers controlled with one controller. The Master-Secondary Array Controller is also applicable for chiller applications that do not require redundant operation and first cost is considered an important factor.

The Master-Secondary Array Controller is powered from the unit supply power and factory provided transformer. The Master-Secondary

array control panel also contains a field connection terminal strip and door-mounted off/auto switch, run indicator light and alarm indicator light.

The Master-Secondary Array Controller is accessed through the keypad display, touchscreen display or PC/laptop. If communication between the individual FWCD Series chiller modules and the Master-Secondary Array Controller is lost, that module will be inoperable until communication to the module is restored. The Master-Secondary Controller will continue to control the other modules in the array. If Master-Secondary Array Controller fails, the array will be down until the controller is repaired or replaced.

N+1 logic can be utilized with the Master-Secondary Array Controller, via the demand limit function, when each chiller in an array is equipped with optional chilled water motorized on-off valve, optional condenser water regulating valve and a standby chiller is installed in the array.



Figure 3 - Master-Secondary Controller Layout

Application Information

Evaporator Design Data

The system can start and pull down with up to 90°F entering fluid temperature. For continuous operation, it is recommended that the entering fluid temperature not exceed 75°F. The maximum sustained leaving chilled-fluid temperature is 65°F. The chiller with *standard* evaporator must not be operated with a leaving water temperature of less than 42°F for a plain water application. The chiller with *high-capacity* evaporator must not be operated with a leaving water temperature of less than 40°F for a plain water application. For evaporator loops containing the appropriate amount of glycol, the chilled water leaving temperature range can be shifted to 15°F to 65°F. When lower leaving fluid temperatures are required, an appropriate glycol solution must be used. The solution must have a freezing point at least 15°F lower than the design leaving fluid temperature. The brine solution must also be properly inhibited to provide suitable corrosion protection.

The evaporator minimum and maximum flow rates are listed in “Table 11 - General Unit Information”. In general, the listed flow rate ranges will develop temperature differentials across the evaporator between 7°F to 20°F. If your application conditions do not fit these requirements, please contact Jetson by Modine.

For all FWCD Series chiller applications, the flow to the evaporator must be proven using a chilled water flow-proving device. A factory-provided paddle style liquid flow switch is provided with a NEMA Type 4X enclosure for field-installation.

Condenser Design Data

Standard condenser entering water temperature range for the FWCD Series chiller is 65°F to 125°F. The condenser leaving water temperature (LWT) maximum is 125°F for shell-and-tube condensers and 140°F for brazed-plate

condensers, and the condenser LWT minimum is 70°F. When the condenser LWT is lower than 70°F, the refrigerant condensing temperature can drop below 80°F and fall outside of the FWCD Series compressor’s operating envelope. For these applications, provisions must be made to control the condenser water that results in a stable refrigerant condensing temperature / pressure that remains above 80°F (235 psig) throughout all steady state, part load and transient operating conditions. The integral factory-installed condenser water regulating valve option is ideal for these applications and is highly recommended.

The condenser minimum and maximum flow rates are listed in “Table 11 - General Unit Information”. In general, the listed flow rate ranges will develop temperature differentials across the condenser between 5°F to 30°F. If your application conditions do not fit these requirements, please contact the Jetson Innovations.

All Jetson modular chillers have two compressors in each individual module. Both of these compressors are served by common water flow. In a typical water-cooled application with nominal water flows of 2.4 gpm/ton through the evaporator BPHE (brazed plate heat exchanger) and 3.0 gpm/ton through the condenser, the delta temperature entering and leaving both heat exchangers will be 10°F with both compressors running, and 5°F with one compressor running.

Condenser Heat Recovery Operation

At a time when energy costs are high and continue to rise, reducing energy usage has become increasingly important. By using a FWCD Series chiller with heat recovery, utilization of energy can be improved by using heat from the condenser that would otherwise be wasted.

The use of heat recovery should be considered in any building with simultaneous heating and cooling requirements or in facilities where heat can be stored and used at a later time. Buildings with high year-round internal cooling loads are excellent opportunities for heat recovery. Heat recovery can be accomplished with the FWCD Series by recovering heat from the water leaving the standard condenser and using it in conjunction with a third party heat exchanger as shown in Figure 4 - Heat Recovery.

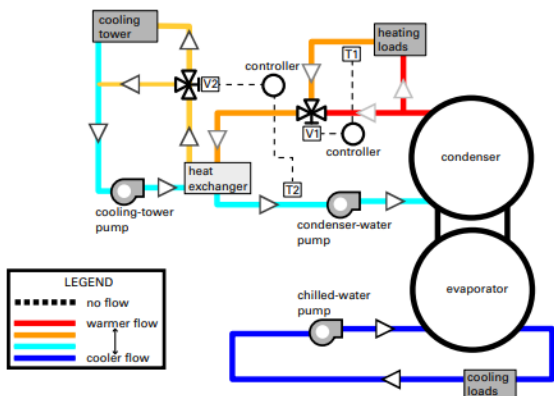

Figure 4 - Heat Recovery

Heat recovery is designed to capture a portion of the heat that is normally rejected to the cooling tower and put it to beneficial use. With the addition of a heat recovery cycle, heat removed from the building cooling load can be transferred to any heating application. The heat recovery cycle is only possible if a cooling load exists to act as a heat source.

The FWCD Series chiller uses smart control logic to switch the control point between the cooling set point and heating set point, based on the smaller of the loads. This allows the machine to operate in heat recovery mode longer - maximizing the energy saved. In the heat recovery cycle, the unit can control to a hot water set point. During the heat recovery cycle, the unit operates just as it does in the cooling-only mode except that the leaving hot water is the control point instead of the leaving chilled water. Water

circulated through the heat recovery heat exchanger (condenser) absorbs cooling load heat from the compressed refrigerant gas discharged by the compressors. The heated water is then used to satisfy heating requirements.

Hospitals, dormitories, computer centers, and hotels are opportunities for economical heat recovery due to their needs for hot water for reheat and domestic use, coupled with air-side economizer operation, or in some cases, winter operation of chillers. Heat recovery provides hot water and tight control that minimizes operating costs for the chilled water plant and boiler/hot water heater, while also providing consistent dehumidification. The heat recovery heat exchanger cannot operate alone without a load on the chiller.

Units with a brazed plate heat recovery heat exchanger can produce up to 140°F leaving water temperature and units with the shell and tube heat recovery heat exchanger can produce up to 125°F leaving temperature.

Fluid Volume

Consideration must be given to the total volume of fluid in the system. In close coupled, low volume systems, the leaving fluid temperature will change quickly with steps of capacity control. This is not acceptable if close control is desired for a conditioned space or an industrial process. In order to accurately determine the fluid volume needed for the application, you must resolve and agree on the amount of swing in fluid temperature that can be tolerated. This will depend on the control system, the terminal equipment operation, and use. For applications utilizing constant flow evaporators, 25% of the design load is the minimum array turndown allowed. If further turndown is required, the system must have variable primary flow and motorized isolation valves on each chiller module.

The FWCD Series chillers contain two (2) compressors per module, and can be configured in arrays containing up to twenty (20) compressors. Use the following example as a guide to determine swing in fluid temperature tolerable.

Use the information in Table 1 that lists the maximum step of capacity in each array and a factor for that model.

FLUID VOLUME EXAMPLE

Problem: An array of three (3) FWCD 45-ton units has a total rated tonnage of $42.7 \times 3 = 128.1$ tons at the operating conditions. The chilled water flow is constant volume. It is desired to have no greater than a $\pm 3^\circ\text{F}$ leaving water temperature variation due to compressor unloading. What is the minimum water volume required in the chilled water loop?

Solution: We use the following equation to determine the minimum allowable water loop volume.

$$\text{Minimum Water Loop Volume} = \frac{\text{Actual Tons} \times (\text{Min. Volume Gal-}^\circ\text{F Swing/Ton})}{\text{Allowable } ^\circ\text{F Swing}}$$

Allowable $^\circ\text{F}$ Swing is specified in the problem statement. With a tolerance of $\pm 3^\circ\text{F}$, the total allowable swing is 6°F .

We select the value of Min. Volume Gal- $^\circ\text{F}$ Swing/Ton from Table 1- Minimum Volume based on the number of modules in the array and the type of flow.

Table 1- Minimum Volume

Number of Modules in Array	Maximum % Capacity Step	Minimum Volume (Gal- $^\circ\text{F}$ Swing)/ton
1	50.00	60.0
2*	25.00	30.0
3	16.67	20.0
4	12.50	15.0
5	10.00	12.0
6	8.33	10.0
7	7.14	8.6
8	6.25	7.5
9	5.56	6.7
10	5.00	6.0

** 25% is the lowest capacity step allowed for constant flow arrays.*

For a constant flow system, the minimum capacity step is 25%, therefore the Minimum Volume = 30 (Gal - $^\circ\text{F}$ deg F Swing)/ton

Thus, we can compute the minimum water loop volume with the known performance of 128.1 tons of cooling at the application conditions:

$$\text{Minimum Water Loop Volume} = 128.1 \text{ tons} \times (30 \text{ Gal} - ^\circ\text{F Swing})/\text{ton} / 6 ^\circ\text{F swing} = 641 \text{ gallons.}$$

Using the minimum turndown of 25% for constant volume systems, this equation can be generalized to a commonly used guideline: *gallons per ton* loop volume. By tabularizing different allowable $^\circ\text{F}$ swings the minimum volume on a gallon per ton basis can be displayed.

Table 2 - Minimum Volume (Gallon/Ton)

Allowable temp. swing above & below setpoint (+/-°F)	Minimum Volume (gallon/ton)
5.0	3.00
4.5	3.33
4.0	3.75
3.5	4.29
3.0*	5.00
2.5*	6.00
2.0*	7.50
1.5	10.00
1.0	15.00
0.5	30.00

* Common value used in HVAC industry

This same detailed equation can be generalized to another common loop volume sizing method: *loop time*. As a general guideline, a minimum 3-minute loop time is required for the evaporator chilled water system. In a typical water-cooled application, the nominal fluid flow through the evaporator is 2.4 gpm/ton.

At nominal flows, a 3-minute loop time is equivalent to a minimum loop volume of 7.2 gallon/ton (2.4 gpm/ton x 3 min = 7.2 gallon/ton) and would have an allowable leaving fluid temperature swing of +/- 4.2°F

At nominal flows, a 2-minute loop time is equivalent to a minimum loop volume of 4.8 gallon/ton. (2.4 gpm/ton x 2 min = 4.8 gallon/ton) and would have an allowable leaving fluid temperature swing of +/- 6.25°F.

Notice, in the preceding example, if this system was selected for a 45°F leaving water temperature, the temperature will vary between 42°F to 48°F (recall the variation tolerance +/- 3°F) with the cycling of the compressors at the water loop volume of 641 gallons. The final selection should ensure the leaving water temperature does not drop below 42°F (or 40°F if using a high capacity evaporator). If a leaving water temperature below 42°F (or 40°F if using a high capacity evaporator) is indicated then the

loop volume should be increased or glycol should be included with the design.

Glycol

If the fluid loop contains glycol, the required water loop volume should be multiplied by the correction factor in Table 3.

Table 3 -Glycol Correction Factors

% by Weight	Glycol Volume Correction Factor	
	Ethylene	Propylene
10	1.038	1.017
20	1.066	1.033
30	1.100	1.058
40	1.140	1.092
50	1.192	1.142

It may be necessary to install a storage tank in the system to provide the necessary volume for close temperature control. When this is done, the tank should be installed in the loop between the fluid leaving from the load and the return to the chiller. *Figure 5- Expansion Tank Usage* illustrates a proper expansion tank usage.

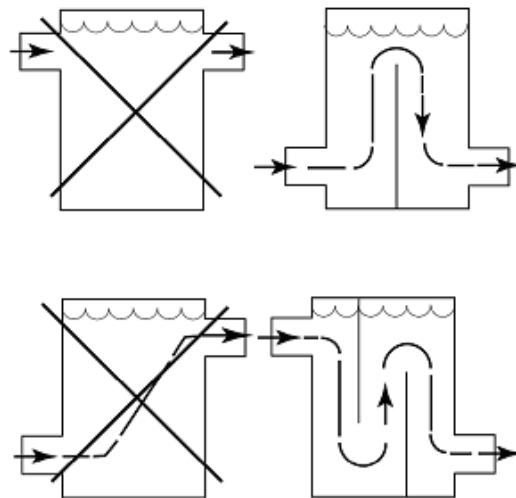

Figure 5- Expansion Tank Usage

Variable Flow

FWCD Series chillers can be applied in variable flow applications where the flow is varied and controlled by others. The flow being delivered to the chiller must not go outside the stated minimum and maximum flow rates in “Table 11 - General Unit Information”. Also, the chilled water system volume should be calculated using the highest evaporator flow rate to be delivered to the chiller, and the rate of change in flow rate must not exceed 10% of design flow gpm per minute.

In FWCD Series chiller arrays, the chillers are piped with a common header. Notice in *Figure 6- Variable Flow with Parallel Pumps* this common header arrangement allows the ability to operate the system in several ways depending on the load and/or current situation. For instance, the system can be operated with two pumps and one chiller so that flow out into the system can be increased, without needing to stage on an additional chiller.

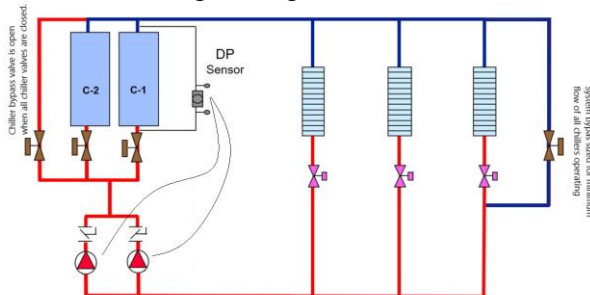

Figure 6- Variable Flow with Parallel Pumps

This configuration also allows flexible redundancy with commonly headered pumps and chillers. If a pump goes down, the remaining pump can serve one or both chillers and still meet the required load. If a chiller needs service or is turned off, the system can compensate for some of the loss in capacity by increasing flow through the remaining chiller while operating both pumps. However, the flow being delivered to any chiller must not go outside the stated minimum and maximum flow rates.

By maintaining the flow between the minimum and maximum flow rates, the chiller is able to provide proper heat transfer and stable operation at lower flows and avoid eroding the pipes at higher flows.

Variable Flow Bypass Valves

A bypass valve is required at the chillers and the load (air handlers, terminal devices, etc.) in systems with variable flow pumping. The bypass must be piped so the temperature and differential pressure sensors are always sensing active flow.

Load Bypass Valve

If a single load side bypass valve is used, it should be sized to bypass the minimum water flow at *maximum* chiller load. This size is required because there can be a lag between the load measured at the system load and at the FWCD Series chiller bank. This lag can create different flow requirements at the load versus the chiller(s).

An example of this lag is when a building becomes occupied in the morning and the chillers are in a pull-down situation. The air handlers serving the occupied space reach the desired occupied temperature and simultaneously drive their control valves closed. At the same time, the chillers are still in a pull-down mode and running at full capacity to reach the desired leaving water temperature. As a result, the chiller(s) require more flow than the rest of the system until the chiller controls unload the chiller to match the new system load condition. Without a system bypass valve, the system pump(s) will either provide too much flow to the load (air handlers, terminal devices, etc.) or not enough flow the chiller array. The bypass valve also ensures that there is an adequate minimum flow thru the pump if all the valves in the load system are closed, otherwise the pumps can deadhead.

Bypass valves at the end of the loop/system, as shown in *Figure 7- Example Load Bypass Valve Arrangements*, promotes keeping the overall

active loop volume high. Some systems may not allow for an end-of-loop bypass. In these situations, the bypass valve may be installed closer to the chiller, provided the minimum system volume equaling a minimum of a 2-3 minute loop time is maintained to ensure proper operation. (See section on “Loop Time” in this catalog for more information.)

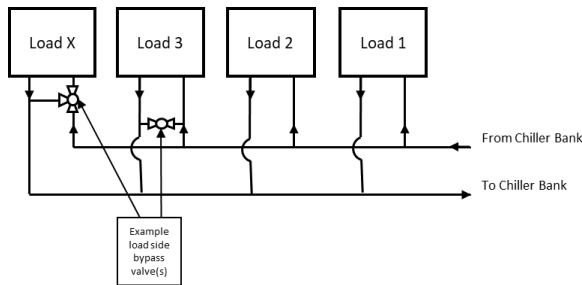

Figure 7- Example Load Bypass Valve Arrangements

External Chiller Array Bypass Valve

A bypass valve for the chiller array is required so that when the chiller array has reached the desired leaving water temperature, and the motorized valves for each module have closed, system flow remains through the external chiller array bypass valve. The chiller bypass should be sized for the minimum flow of one chiller module or the minimum flow of the system’s pumping system, whichever is greater. This bypass is only required to be open when all motorized valves in the chiller array are closed. After the first module is active and the motorized valves are the open, the external chiller array bypass valve can be closed because the active module now provides the water flow path.

Water Circuit Requirements

FWCD Series modular chillers are equipped with brazed plate evaporators. The water/fluid circuits to be used with these chillers should be designed and installed following sound engineering practices and procedures as well as any applicable local and industry standards. For the brazed plate heat exchanger circuits, focus on proper filtration and water quality is necessary. Prior to connecting a FWCD Series modular

chiller into a newly installed or existing water piping system, it is required to flush the system with a detergent and hot water mixture to remove previously accumulated dirt and other organics. In old piping systems with heavy encrustation of inorganic materials, a water treatment specialist should be consulted for proper passivation and/or removal of these contaminants.

Filtration

Particulate fouling is caused by suspended solids (foulants) such as mud, silt, sand or other particles in the heat transfer medium. The best way to avoid particulate fouling is to have good water treatment and keep all system water clean and with open loop system water, maintain proper bleed rates and make up water. A strainer with a 20-mesh screen (or screen with 0.5 mm sized openings or less) is required to be installed at the individual compact chiller (or compact chiller array) inlet to protect the brazed plate heat exchangers. Wye-strainers are available as a factory-provided, field-installed option. If an application is highly susceptible to foulant contamination, additional filtration methods should be investigated.

Water quality

Poor water quality can cause another type of fouling called scaling. Scaling is caused by inorganic salts in the water circuit of the heat exchangers. Scaling increases pressure drop and reduces heat transfer efficiency. The likelihood of scaling increases with increased temperature, concentration and pH. In addition to scaling, poor water quality can cause other issues like biological growths and corrosion. Therefore, water quality and water quality control needs to be an application consideration. Please review the water quality requirements for use with the brazed plate heat exchangers on the FWCD Series modular chiller.

Table 4 -Water Property Limits

Water Property	Concentration Limits
Alkalinity (HCO ₃ ⁻)	70-300 ppm
Sulfate (SO ₄ ²⁻)	Less than 70 ppm
HCO ₃ ⁻ / SO ₄ ²⁻	Greater than 1.0
Electrical Conductivity	10 - 500 μS/cm
pH	7.5 – 9.0
Ammonia (NH ₃)	Less than 2 ppm
Chlorides (Cl ⁻)	Less than 300 ppm
Free Chlorine (Cl ₂)	Less than 1 ppm
Hydrogen Sulfide (H ₂ S)	Less than 0.05 ppm
Free (aggressive) Carbon Dioxide (CO ₂)	Less than 5 ppm
Total Hardness (°dH)	4.0 - 8.5
Nitrate (NO ₃)	Less than 100 ppm
Iron (Fe)	Less than 0.2 ppm
Aluminum (Al)	Less than 0.2 ppm
Manganese (Mn)	Less than 0.1 ppm

Oversizing Chillers

Generally speaking, fully loaded equipment operates more efficiently than large equipment running at or near minimum capacity. When selecting a chiller, the anticipated part load operation of the system should be evaluated with respect to the NPLV rating of the equipment under consideration. Larger future loading requirements may cause temporary oversizing of equipment that is initially selected and installed. This should be done with care, although the FWCD Series array chiller, with multiple scroll compressors, is more tolerant than designs that use a single compressor or a few larger compressors.

Chiller Placement

The FWCD Series water-cooled chillers are designed for indoor installations that remain above 32°F and below 125°F at all times. Locate the chiller away from sound-sensitive areas on a level foundation or flooring strong enough to support 150 percent of the operating weight and large enough to keep with service clearances. Also, the chiller foundation or flooring must be rigid enough to minimize vibration transmission. Please see General Data chapter for compressor sound data and Dimension and Weights information for unit operating weights and

clearances. If necessary, options are available for sound attenuation and vibration reduction.

Be sure to observe the dimensions that are on the rating plate of the chiller for operational and service clearances. For proper unit operation, the immediate area must remain free of debris Table A4 displays the typical clearances found on the rating plate of each unit.

Table 5 -Service Clearances

Location	Required	Recommended
Back	0"	24"
Front	42"	53"
Left	0"	36"
Right	0"	36"
Top	36"	36"

Mounting Isolation

Anytime vibration transmission may be a factor, vibration isolators may be considered. Rubber isolators are available as factory provided options.

Electrical Power Supply

A disconnect switch that is accessible from the outside of the cabinet is an available option factory installed. The microprocessor controller furnished with the unit is supplied with its own power supply factory wired to the main power of the chiller. The voltage to the chiller must be within plus or minus 10% of the nameplate rating value on the unit. All FWCD Series chiller arrays are available with a single point power supply or each module may be powered individually. The largest capacity single point power supply terminal supplied from Jetson is rated at 1200 amps.

Optional Oversized Evaporator

These heat exchangers are available on all model sizes except the 85 ton. They may be selected for improved performance with water or they may be selected for use with systems that contain glycol to aid in offsetting the decreased capacity due to

the thermal properties of glycol. Oversized evaporators also allow a 40F leaving water temperature without the requirement for glycol.

Air-Cooled Condenser Applications

The FWCD Series chillers can be paired with remote air-cooled condensers. The minimum outdoor ambient temperature for operation of a FWCD Series compressor chiller in combination with an outdoor condenser is 20°F. This minimum is driven by compressor chiller starting considerations and not by effectiveness of condenser ambient controls once the system is up and running. Fan cycling and optional low ambient dampers do *not* mitigate the low ambient starting problem. On a cold day with outdoor ambient temperature below 20°F the liquid line pressure at the expansion valve inlet is extremely low. On start, the suction pressure may plunge into the freezing range causing a nuisance fault. The maximum ambient temperature limit for the FWCD is 110°F.

Line Sizing Guidelines

Liquid Lines

Pressure drop should not be so large as to cause gas formation in the liquid line, insufficient liquid pressure and the liquid feed device, or both. Systems are normally designed so that pressure drop in the liquid line from friction is not greater than that corresponding to 1 to 2°F change in saturation temperature.

Sufficient sub-cooling must be maintained at the expansion valve. To provide proper operation throughout the range of operating conditions, the liquid-line pressure drop should not exceed the unit's minimum sub-cooling value less 5°F. To achieve this objective, keep these liquid line considerations in mind:

- 1) Select the smallest, practical line size for the application. Limiting the refrigerant charge improves compressor reliability.
- 2) When designing the liquid line for a typical air conditioning application (i.e., one with an

operating range of 40°F to 110°F), remember that every 10 feet of vertical rise will reduce sub-cooling by 2.8°F, while every 10 feet of vertical drop will add 1.1°F of subcooling.

- 3) Provide a 1-inch pitch toward the evaporator for every 10 feet of run.
- 4) If the liquid line must be routed through an area warmer than outdoor air temperature, insulate the line to prevent the refrigerant from flashing. A liquid line filter drier must be installed as close as possible to the compressor chiller. The filter drier should be changed whenever the system is opened for service. FWCD Series compressor chillers do not include a filter-drier as standard, but one may be ordered if the installing contractor desires a factory type.
- 5) A moisture-indicating sight glass permits a visual check of the liquid column for bubbles. Sight glasses are included on the FWCD Series compressor-chiller. Never use the sight glass to determine whether the system is properly charged! Instead, either charge the system based on the required sub-cooling or calculate the amount of refrigerant needed and add it based on weight.

Discharge (Hot Gas) Line

Limit the pressure drop in the discharge line to 6 psig whenever possible to minimize the adverse effect on unit capacity and efficiency. While a pressure drop of as much as 10 psig is usually permissible, note that a 6-psig pressure drop reduces unit capacity by 0.9 percent and efficiency by 3.0 percent.

Pitch discharge lines in the direction of hot gas flow at the rate of 1/2-inch per each 10 feet of horizontal run. Discharge line sizing is based on required velocity to provide good oil movement. Basic discharge line parameters are:

- Maximum allowable pressure drop 6 psig (°F)
- Maximum Velocity 3500 fpm
- Minimum Velocity (at minimum load)
 - Horizontal lines 500 fpm
 - Vertical lines (up flow) 1000 fpm

To design the discharge line properly, follow the recommended guidelines:

- 1) Choose the shortest route from the compressor to the condenser.
- 2) Use different pipe sizes for horizontal and vertical lines to make it easier to match line pressure drop and refrigerant velocity to discharge-line requirements.
- 3) To assure proper oil entrainment and avoid annoying sound levels, size the discharge line so refrigerant velocity equals or exceeds the Table 6 minimum velocity of 1000 fpm in vertical (up flow) lines and 500 fpm in horizontal (or drop) line and remains below 3500 fpm.
- 4) Prevent oil and condensed refrigerant from flowing back into the compressor during “off” cycles by:
 - pitching the discharge line toward the condenser, and
 - routing the discharge line so that it rises to the top of the level of the condenser inlet, creating an inverted trap.
- 5) Double risers are generally unnecessary. The scroll compressors in FWCD Series chillers unload to the extent that a single, properly sized riser can transport oil at any load condition.
- 6) Riser traps are also unnecessary. Avoid using riser traps. If the discharge riser is sized to maintain the proper refrigerant velocity, adding a trap will only increase the pressure drop.

Table 6 – Minimum discharge line velocities for oil entrainment

Nominal Pipe Size (in.)	Riser Refrigerant Velocity (fpm)	Horizontal Refrigerant Velocity (fpm)
7/8	375	285
1-1/8	430	325
1-3/8	480	360
1-5/8	520	390
2-1/8	600	450

R-454B Line Sizing Charts

Table 7 – R-454B Line Sizing Single Circuit FWCD

Unit Nom. Tons	Chiller Connection Size (od)		0-50 Equiv. Pipe Length (ft)		50-100 Equiv. Pipe Length (ft)		100 - 150 Equiv. Pipe Length (ft)	
	Liquid (in.)	Discharge (in.)	Liquid (in.)	Discharge (in.)	Liquid (in.)	Discharge (in.)	Liquid (in.)	Discharge (in.)
20	3/4	1-1/8	3/4	1-1/8	3/4	1-3/8	7/8	1-3/8
30	7/8	1-3/8	7/8	1-3/8	7/8	1-5/8	7/8	1-5/8
45	1-1/8	1-3/8	1-1/8	1-5/8	1-1/8	1-5/8	1-1/8	2-1/8
55	1-1/8	1-3/8	1-1/8	1-5/8	1-1/8	2-1/8	1-3/8	2-1/8
65	1-1/8	2-1/8	1-1/8	1-5/8	1-1/8	2-1/8	1-3/8	2-1/8
75	NA							
85								

Note: Line sizes may differ if unit is equipped with hot gas bypass or unit has operation below 40°F leaving fluid temperature.

Table 8 - R-454B Line Sizing Dual Circuit FWCD Series

Unit Nom. Tons	Chiller Connection Size (od)		0-50 Equiv. Pipe Length (ft)		50-100 Equiv. Pipe Length (ft)		100 - 150 Equiv. Pipe Length (ft)	
	Liquid (in.)	Discharge (in.)	Liquid (in.)	Discharge (in.)	Liquid (in.)	Discharge (in.)	Liquid (in.)	Discharge (in.)
20	5/8	1-1/8	5/8	1-1/8	5/8	1-1/8	5/8	1-1/8
30	3/4	1-1/8	5/8	1-1/8	3/4	1-1/8	3/4	1-3/8
45	3/4	1-1/8	3/4	1-1/8	7/8	1-3/8	7/8	1-3/8
55	7/8	1-1/8	7/8	1-3/8	7/8	1-3/8	1-1/8	1-5/8
65	7/8	1-3/8	7/8	1-3/8	7/8	1-5/8	1-1/8	1-5/8
75	1-1/8	1-3/8	1-1/8	1-3/8	1-1/8	1-5/8	1-1/8	1-5/8
85	1-1/8	1-3/8	1-1/8	1-5/8	1-1/8	1-5/8	1-1/8	2-1/8

Note: Line sizes may differ if unit is equipped with hot gas bypass or unit has operation below 40°F leaving fluid temperature.

Multiple Chiller Applications

When more than one (1) FWCD Series chiller is piped together (to form an array of chillers) for higher capacity and/or redundant chiller applications, an array controller package must be provided from the factory. A Master-Secondary controller can control up to six (6) units in an array. A Supervisor controller can control up to ten (10) units in an array.

The number of compact chillers that can be physically piped together to form an array and share a common header is limited to approximately 300 total tons or 900 gpm. In general, if the total tonnage is 300 tons or less or 900 gpm or less, one common evaporator supply/return line and one

common condenser supply/return line can be used. If the total tonnage needed is greater than 300 tons or 900 gpm, the flow from these common lines can be split between two arrays of chillers. Array water line sizing is based on a 3 gpm ton condenser flow and a velocity limitation of 10 feet per second. Figure 8 - Array Piping shows examples of acceptable array piping configurations. For help with determining the most effective array configuration for your application, please contact the factory.

Figure 8 - Array Piping

COMMON SUPPLY/RETURN

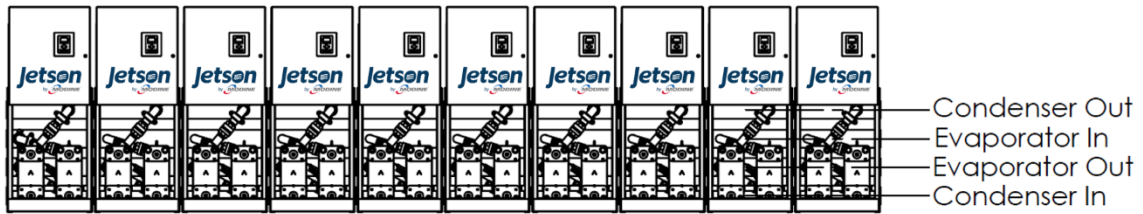

SPLIT SUPPLY/RETURN

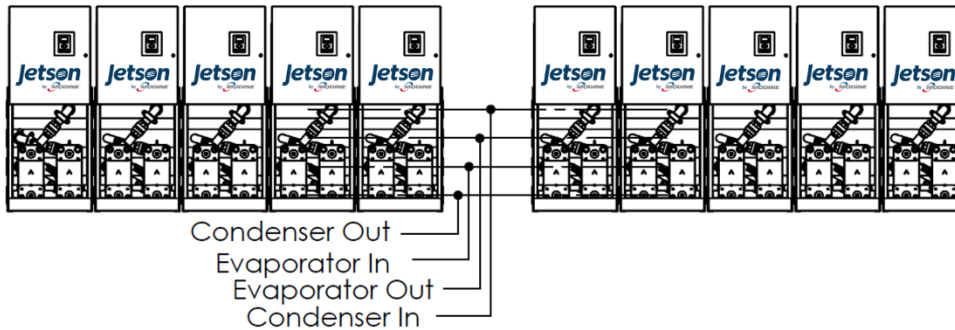

Table 9 - Maximum number of units operating on common supply/return line

Nominal Capacity (tons)	Maximum number of units operating on COMMON supply / return line	Maximum number of units operating on SPLIT supply / return line*
20	10	10
30	10	10
45	8	10
55	6	10
65	5	10
75	4	8
85	3	6

* With split header array piping, the limitation of 10 units is based on the controller capability, not the flow velocity limit of 10fps.

Model Number Descriptions

Digits 1 to 4— Model FWCD

Digits 5 to 7 — Nominal Capacity

020 = 20 Nominal Tons
 030 = 30 Nominal Tons
 045 = 45 Nominal Tons
 055 = 55 Nominal Tons
 065 = 65 Nominal Tons
 075 = 75 Nominal Tons
 085 = 85 Nominal Tons

Digit 8 — Unit Voltage

A = 208 V/60 Hz/3 Phase
 B = 230 V/60 Hz/3 Phase
 F = 460 V/60 Hz/3 Phase
 G = 575 V/60 Hz/3 Phase

Digits 9 — Unit Application

A = Water-Cooled Chiller
 B = Compressor Chiller with Remote Condenser (40°F to 115°F)
 D = Compressor Chiller with Remote Condenser (20°F)

Digit 10 — Refrigeration Style

G = R-454B Scroll
 H = R-454B Variable Speed (Lead Circuit)

Digit 11 — Number of Circuits

1 = Single Circuit
 2 = Dual Circuit

Digit 12 — Efficiency/Capacity

1 = Standard Efficiency
 2 = High-Capacity Evaporator (allows 40F leaving water)

Digit 13 — Design Sequence

0 = Factory Assigned

Digit 14 — Array System

0 = Non-Array System
 1 = Array System

Digit 15 — Evaporator Heat Exchanger Type

0 = Brazed Plate

Digit 16 — Evaporator Fluid Type

0 = Water
 2 = Ethylene Glycol
 3 = Propylene Glycol

Digit 17 — Evaporator Flow

0 = Constant Flow Primary
 1 = Variable Flow Primary

Digit 18 — Evaporator Temperature Range

0 = Standard Cooling
 40 to 65°F [5.5 to 18.3°C]
 1 = Standard Cooling/Ice Making
 20 to 65°F [-6.7 to 18.3°C]

Digit 19 — Evaporator Control Valves

0 = No Valves (Standalone Chiller)
 1 = Manual Balancing Isolating Valves
 2 = Motorized Chilled Water Isolating Valve

Digit 20 — Condenser Heat Exchanger Type

0 = Brazed Plate
 1 = Shell and Tube
 5 = Remote Condenser

Digit 21— Condenser Fluid Type

0 = Water
 2 = Ethylene Glycol
 3 = Propylene Glycol
 9 = Not Applicable — Compressor-Chiller

Digit 22 — Condenser Heat Recovery

0 = No Heat Recovery
 1 = Heat Recovery

Digit 23 — Condenser Corrosion Resistance

0 = Standard
 1 = Cupro-Nickel (Avail. Shell and Tube Only)

Digit 24 — Condenser Control Valves

0 = No Valves (Standalone Chiller)
 1 = Manual Valve
 2 = Motorized Head Pressure Control Valve

Digit 25 — Power Feed

0 = Single Point Power (5 kA Rating)
 A = Single Point Power (5 kA Rating) + Phase and Voltage Monitor
 B = Single Point Power (100 kA Rating)
 C = Single Point Power (100 kA Rating) + Phase and Voltage Monitor
 D = Power Feed to Each Unit (5 kA Rating)
 E = Power Feed to Each Unit (5 kA Rating) + Phase and Voltage Monitor
 F = Power Feed to Each Unit (100 kA Rating)
 G = Power Feed to Each Unit (100 kA Rating) + Phase and Voltage Monitor

Digit 26 — Power Connection

0 = Terminal Block
 A = Non-Fused Disconnect Switch
 B = Fused Disconnect Switch

C = High SCCR Fuse Block
 D = Distribution Panel Connection = Terminal Block; Module Power Connection = Circuit Breaker

Digit 27 — Service Options

0 = None
 A = LED Lighted Control Cabinet

Digit 28 — Panel Ampere Rating

0 = None
 D = 250 Amp
 E = 400 Amp
 F = 600 Amp
 G = 800 Amp
 H = 1200 Amp

Digit 29 — Control Style

0 = Master Secondary Controller w/ Single Controller per Array
 A = Supervisory Array Controller w/ Controller per Module
 B = Non-Array, Single Unit Controller

Digit 30 — Local Unit Controller Interface

0 = Keypad with Dot Pixel Display
 B = 15.4-in. Color Touchscreen

Digit 31 — Remote BMS Interface (Digital Comm)

0 = None
 2 = Lon Talk®
 4 = BACnet® MS/TP
 5 = BACnet® IP
 6 = MODBUS®
 8 = Johnson N2

Digit 32 — Blank

0 = Blank

Digit 33 — Blank

0 = Blank

Digit 34 — Refrigeration Options

1 = Active Freeze Protection (All Circuits)
 2 = Hot Gas Bypass (All Circuits)

Digit 35 – Refrigeration**Accessories**

0 = Moisture Indicating Sight Glass
 A = Moisture Indicating Sight Glass + Compressor Isolation Valves
 B = Moisture Indicating Sight Glass + Replaceable Core Filter Driers
 C = Moisture Indicating Sight Glass + Replaceable Core Filter Driers + Compressor Isolation Valves

Digit 36 – Water Connection

0 = Grooved Pipe Connection, Standard Header Length
 A = Grooved Pipe Connection, Extended Header Length
 D = No Header Piping (Heat Exchangers Only)

Digit 37 – Water Side Pressure

0 = 150 psi
 A = 300 psi

Digit 38 – Water Strainer(s)

0 = None
 A = Chilled Water Flow Wye Strainer
 B = Chilled Water Wye Strainer with Installation Kit
 C = Condenser Water Flow Wye Strainer
 D = Condenser Water Wye Strainer with Installation Kit
 E = Chilled and Condenser Water Nominal Flow Wye Strainer
 F = Chilled and Condenser Water Wye Strainer with Installation Kit

Digit 39 – Water Accessories

0 = Chilled Water Flow Switch
 B = Analog Water Temperature Gauge
 C = Analog Water Pressure Gauge
 E = Chilled Water Flow Switch + Analog Water Temperature Gauge
 F = Chilled Water Flow Switch + Analog Water Pressure Gauge
 Analog Water Temperature Gauge
 J = Chilled Water Flow Switch + Analog Water Temp Gauge + Analog Water Pressure Gauge

Digit 40 – Blank

0 = Blank

Digit 41 – Sound Attenuator

0 = None
 A = Compressor Sound Blankets
 B = Factory Sound Enclosure Cabinet
 C = Compressor Sound Blankets + Factory Sound Enclosure Cabinet

Digit 42 – Unit Mounting

0 = None
 A = Neoprene Pads
 B = Leveling Kit
 C = Casters/Wheels
 D = Neoprene Pads and Casters/Wheels
 E = Neoprene Pads and Leveling Kit

Digit 43 – Exterior Finish and Shipping Splits

0 = Standard Paint, Each Module Packaged Separately
 B = Custom Paint, Each Module Packaged Separately

Digit 44 – Shipping Options

A = Framed Crate with Plastic Wrap (Non-Shrink)
 D = Fully Enclosed Crate

Digit 45 – Warranty

0 = Standard Warranty
 A = Five Year Compressor Only Parts Warranty (AC)
 B = Factory Startup + Owner Training + Two Year Parts & Labor Warranty
 C = Factory Startup + Owner Training + Three Year Parts & Labor Warranty
 D = Factory Startup + Owner Training + Four Year Parts & Labor Warranty
 E = Factory Startup + Owner Training + Five Year Parts & Labor Warranty
 F = Factory Startup + Two Year Parts & Labor Warranty

G = Factory Startup + Three Year Parts & Labor Warranty
 H = Factory Startup + Four Year Parts & Labor Warranty
 J = Factory Startup + Five Year Parts & Labor Warranty
 K = Factory Startup + First Year Labor Only Warranty
 L = Factory Startup + Owner Training + First Year Labor Only Warranty
 M = Factory Startup + Owner Training + Two Year Parts Only Warranty
 N = Factory Startup + Owner Training + Three Year Parts Only Warranty
 P = Factory Startup + Owner Training + Five Year Parts Only Warranty
 Q = Factory Startup + Two Year Parts Only Warranty
 R = Factory Startup + Three Year Parts Only Warranty
 S = Factory Startup + Five Year Parts Only Warranty
 T = Factory Startup + Five Year Compressor Only Parts Warranty (AC)
 U = Factory Startup + Owner Training + Five Year Compressor Only Parts Warranty (AC)
 V = Factory Startup Service + 1 Year Parts Only Warranty
 W = Factory Startup Service w/Owner Training + 1 Year Parts Only Warranty
 X = Two Year Parts Only Warranty
 Y = Three Year Parts Only Warranty
 Z = Five Year Parts Only Warranty

Digit 46 – Special Options

0 = None
 X = With Specials

Digits 5 to 7 — Nominal Capacity

The first numbers of the model string designate nominal tons cooling. Actual capacities will vary with conditions.

Table 10 - Model Sizes

Model	Nominal Tons at AHRI	Compressors	Circuits
FWCD-020	21.4	2	1 or 2
FWCD-030	30.9		
FWCD-045	41.4		
FWCD-055	50.5		
FWCD-065	63.3		
FWCD-075	73.0		2
FWCD-085	82.8		2

*Note: The nominal capacities reflect the use of R-454B refrigerant and a standard heat exchanger for dual circuited-units.

Digit 8 — Unit Voltage

All units have single point power blocks with grounding lugs and 12V control circuits.

A = 208 V/60 Hz/3 Phase

B = 230 V/60 Hz/3 Phase

F = 460 V/60 Hz/3 Phase

G = 575 V/60 Hz/3 Phase

Digit 9 — Unit Application

A = Water-Cooled Chiller – Standard water-cooled chiller with optional shell and tube condenser or brazed plate condenser and brazed plate evaporator.

B = Compressor Chiller with Remote Condenser – FWCD chillers can be configured without a condenser and mated with an air-cooled condenser.

Digit 10 — Refrigerant Style

G = R-454B Scroll - One fixed speed compressor on first refrigeration circuit; One fixed speed compressor on second refrigeration circuit

H= R-454B Variable Speed Scroll (Lead Circuit)- One variable speed compressor on first refrigeration circuit; One fixed speed compressor on second refrigeration circuit

Digit 11 — Number of Circuits

1 = Single Circuit – Two compressors per module are piped on a single, tandem circuit to single circuit evaporators and condenser.

2 = Dual Circuit – Two compressors per module are piped independently to dual circuit evaporator and condenser.

Digit 12 — Efficiency/Capacity

1 = Standard Efficiency – Standard sized evaporator.

2 = High-Capacity Evaporator – High-capacity evaporator for glycol applications or for 40F leaving water applications.

Digit 13 — Design Sequence

0 = Factory Assigned

Digit 14 — Array System

0 = Non-Array System – FWCD chillers can be applied in standalone applications needing between 20 to 75 tons of cooling. In standalone applications, chiller headers are not required and the “no header” option can be selected in Digit 36.

1 = Array System - More than one FWCD modular chiller may be piped together (to form an array of chillers) for higher capacity and/or redundant chiller applications, an array controller package must be provided from the factory. The number of modular chillers that can be physically piped together to form an array and share a common header is limited to approximately 300 total tons or 900 gpm.

Digit 15 — Evaporator Heat Exchanger Type

0 = Brazed Plate - Brazed plate heat exchangers are one of the most efficient ways to transfer heat. They are designed to provide unparalleled performance with the lowest life-cycle cost.

Digit 16 — Evaporator Fluid Type

0 = Water

2 = Ethylene Glycol

3 = Propylene Glycol

Digit 17 — Evaporator Flow

0 = Constant Flow Primary - Constant flow pumping systems utilize a staged cooling system and a constant flow water pumping system. No modules are isolated at part load. Flow from “off” chillers mixes with the flow from active chillers in creating the leaving array temperature. The load may not be less than 25% of the full load in constant flow applications.

1 = Variable Flow Primary - Variable flow systems utilize compressor staging and motorized isolation valves with a variable flow water pumping system to modulate cooling and water flow to meet chilled water needs and save operating energy costs. Cooling capacity is modulated by staging compressors and isolating modules based on the desired leaving water temperature. Water flow control is field provided and is usually modulated with VFD controlled variable flow primary pumps based on the differential pressure across the water system.

Digit 18 — Evaporator Temperature Range

0 = Standard Cooling 40 to 65°F [5.5 to 18.3°C] – The chiller with *standard* evaporator must not be operated with a leaving water temperature of less than 42°F for a plain water application. The chiller with *high capacity* evaporator must not be operated with a leaving water temperature of less than 40°F for a plain water application.

1 = Standard Cooling/Ice Making 20 to 65°F [-6.7 to 18.3°C] - The dual roles of an ice-making chiller can substantially reduce the installed cost of the system. An ice-making chiller is NOT a conventional chiller with two different leaving-fluid temperature setpoints. An ice-making chiller operates at maximum capacity when in ice-making mode. It continues to operate at maximum capacity until the leaving-fluid temperature reaches the target setpoint. At a 10°F delta across the evaporator, this limit indicates that all of the water inside the ice storage tanks has been frozen. An external signal can be sent to the chiller to reset the chilled water setpoint back to conventional chilled water leaving fluid temperature and the chiller will return to traditional chiller operation.

Digit 19 — Evaporator Control Valves

0 = No Valves (Standalone Chiller) – Balancing / isolating valves are not required when chiller is used in single unit configuration.

1 = Manual Balancing Isolating Valves - For a proper hydronic balance in a constant flow system, manual balancing valves are factory installed in array headers. These valves can also be used to isolate a module in an array for service or cleaning.

2 = Motorized Chilled Water Isolating Valve - Variable flow systems isolate modules not needed to meet current cooling or heating capacity by isolating modules with a factory installed motorized on-off valve.

Digit 20 — Condenser Heat Exchanger Type

0 = Brazed Plate – Brazed plate heat exchanger with grooved pipe water connections.

1 = Shell and Tube - Shell and tube heat exchanger with grooved pipe water connections.

5 = Remote Condenser – Water-cooled condenser is removed and discharge and liquid line connections are provided for connection to remote air-cooled condenser.

Digit 21— Condenser Fluid Type

0 = Water

2 = Ethylene Glycol

3 = Propylene Glycol

9 = Not Applicable — Compressor-Chiller

Digit 22 — Condenser Heat Recovery

0 = No Heat Recovery – Chiller operates to maintain chilled water temperature. Condenser water temperature is unmonitored.

1 = Heat Recovery - Instead of rejecting heat to the cooling tower, heat is recovered from the condenser water and can be used in many commercial facilities for preheating incoming air, washing, showering, and other everyday usage. Such facilities include:

- Hospitals, laundry, showers, and sterilization (often separate from other systems)
- Dormitories: laundry, showers, and general usage
- Hotels: laundry, showers, pool heat, and general usage
- All of these facilities require large quantities of makeup water that must be heated.

Digit 23 — Condenser Corrosion Resistance

0 = Standard

1 = Cupro-Nickel (Avail. Shell and Tube Only) - In applications that can cause chemical corrosion, galvanic corrosion and erosion, the FWCD Series chiller is available with a shell and tube condenser that has high-resistance material tubes consisting of cupro-nickel (Cu/Ni 90/10).

Digit 24 — Condenser Control Valves

0 = No Valves (Standalone Chiller) – Balancing / isolating valves are not required when chiller is used in single unit configuration.

1 = Manual Valve - For a proper hydronic balance in a constant flow system, manual balancing valves are factory installed in array headers. These valves can also be used to isolate a module in an array for service or cleaning.

2 = Motorized Head Pressure Control Valve - The integral condenser water regulating valve option is available to stabilize and maintain the refrigerant condensing pressure within the operating limits of the FWCD Series modular chiller. The valve will replace one of the manual isolating valves that come standard on every chiller and can also be used to isolate the condenser from the cooling water circuit when needed.

Digit 25 — Power Feed

0 = Single Point Power (5 kA Rating) - This option reduces the amount of installation labor by eliminating the need to run separate power to each module in the chiller array. A single connection point is provided to power the array. With this option, the array of chillers is delivered with a separate power panel enclosure. This separate enclosure includes the electrical lug to land the incoming power cables. The cabinet has circuit breakers for each module in the array. Power wiring will be distributed to each chiller module through a wire chase that is part of each individual chiller control panel. Upon installation, the factory supplied electrical whips will be routed to each module through control panels. Conduits are also factory provided to encase the power wiring as it is routed between one chiller module and the next.

A = Single Point Power (5 kA Rating) + Phase and Voltage Monitor - This option includes the single-point power distribution panel. A factory-installed phase/power monitor designed to protect the chiller from premature failure and damage due to common voltage faults such as voltage unbalance, over/under voltage, phase loss, reversal, incorrect sequencing and rapid short cycling is included.

B = Single Point Power (100 kA Rating) - Short-circuit current ratings provide the level of fault current that a component or piece of equipment can safely withstand (based on a fire and shock hazard external

to the enclosure). A 100kA SCCR can have significant impact in meeting safety and insurance requirements.

C = Single Point Power (100 kA Rating) + Phase and Voltage Monitor - This option includes the single-point power distribution panel and each unit is rate for 100ka SCCR. A factory-installed phase/power monitor designed to protect the chiller from premature failure and damage due to common voltage faults such as voltage unbalance, over/under voltage, phase loss, reversal, incorrect sequencing and rapid short cycling is included.

D = Power Feed to Each Unit (5 kA Rating) – Power is field provided to each chiller module in the array. This is beneficial in applications where redundancy or dual point power is desirable or to allow for smaller electrical feeds instead of a large single electrical feed.

E = Power Feed to Each Unit (5 kA Rating) + Phase and Voltage Monitor - This option includes field provided power and an additional factory-installed phase/power monitor designed to protect the chiller from premature failure and damage due to common voltage faults such as voltage unbalance, over/under voltage, phase loss, reversal, incorrect sequencing and rapid short cycling.

F = Power Feed to Each Unit (100 kA Rating) - Short-circuit current ratings provide the level of fault current that a component or piece of equipment can safely withstand (based on a fire and shock hazard external to the enclosure). A 100kA SCCR can have significant impact in meeting safety and insurance requirements.

G = Power Feed to Each Unit (100 kA Rating) + Phase and Voltage Monitor - This option includes field provided power and an additional factory-installed phase/power monitor designed to protect the chiller from premature failure and damage due to common voltage faults such as voltage unbalance, over/under voltage, phase loss, reversal, incorrect sequencing and rapid short cycling.

Digit 26 — Power Connection

0 = Terminal Block - Terminal Block to land incoming power wiring.

A = Non-Fused Disconnect Switch - Non-fusible disconnect switches do not incorporate fuses into their enclosure and provide no circuit protection capability. The purpose of a non-fusible safety switch is to provide an easy means to open and close a circuit.

B = Fused Disconnect Switch - Fusible disconnect switches combine fuses with the switch in a single enclosure, providing an easy means to manually open and close the circuit while the fuses protect against overcurrent.

C = High SCCR Fuse Block - Short-circuit current ratings provide the level of fault current that a component or piece of equipment can safely withstand (based on a fire and shock hazard external to the enclosure). A 100kA SCCR can have significant impact in meeting safety and insurance requirements.

D = Distribution Panel Connection = Terminal Block; Module Power Connection = Circuit Breaker – This feature is used for the single point power options in Digit 25. Factory provided panelboard serves as a power distribution panelboard for chiller array.

Digit 27 — Service Options

0 = None

A = LED Lighted Control Cabinet - LED lights provide bright lighting inside enclosure offer with long service life and can provide improve safety and visibility when service inside the enclosure is needed.

Digit 28 — Panel Ampere Rating

Panelboard rating for single point power. Panel is factory sized and provide when single point power option is selected.

0 = None

D = 250 Amp

E = 400 Amp

F = 600 Amp

G = 800 Amp

H = 1200 Amp

Digit 29 — Control Style

0 = Master Secondary Controller w/ Single Controller per Array - This option allows up to six (6) FWCD modular chillers to be controlled and operated. The Master-Secondary Array Controller requires only a single controller for the array. This option is beneficial in replacement applications where a single larger chiller, with one controller, is replaced by modular chillers controlled with one controller.

A = Supervisory Array Controller w/ Controller per Module - This option allows up to ten (10) FWCD modular chillers to be controlled and operated. The Supervisory Array Controller requires each module have an individual unit controller. This option is beneficial in applications requiring seven (7) or more modules to be controlled and in applications where chiller uptime is critical. If communication between the individual FWCD modular chiller unit controller(s) and the Supervisory Array Controller is lost, or the Supervisory Array Controller fails, the individual FWCD modular chillers can be shifted into manual mode to operate independent from the Supervisory Array Controller and will maintain a “manual mode” default chilled leaving water temperature set point.

B = Non-Array, Single Unit Controller – Standalone Controller has control board with twelve 0-5vdc sensor inputs, four 5vdc digital inputs, ten 230vac 6.3amp relay outputs, four 0-10vdc analog outputs, keypad, 128 x 64 dot pixel STN monochrome graphics LCD with 2.8" diagonal viewing area, real time clock, MCS-I/O, RS-232, RS-485 and Ethernet communication ports.

Digit 30 — Local Unit Controller Interface

0 = Keypad with Dot Pixel Display - keypad, 128 x 64 dot pixel STN monochrome graphics LCD with 2.8" diagonal viewing area

B = 15.4-in. Color Touchscreen - Information and graphics are shown on high resolution (1280x800) LCD display with LED back lighting. The high-resolution screen makes it easy for the user to manage complex installations without losing the overall view or requiring a separate laptop. Pages can be navigated in a fast and straightforward manner.

Digit 31 — Remote BMS Interface (Digital Comm)

- 0 = None**
- 2 = Lon Talk®**
- 4 = BACnet® MS/TP**
- 5 = BACnet® IP**
- 6 = MODBUS®**
- 8 = Johnson N2**

Digit 32 — Blank

- 0 = Blank**

Digit 33 — Blank

- 0 = Blank**

Digit 34 — Refrigeration Options

1 = Active Freeze Protection (All Circuits) – Active freeze protection is a suction pressure-based freeze protection. Active Freeze Protection is standard on all FWCD Series chillers. The chiller's unit controller continually monitors the saturated suction pressure and will open (energize) the Active Freeze Protection solenoid if the suction pressure falls to approximately 101 psig (32°F). The solenoid closes (de-energizes) when the pressure climbs to approximately 105 psig (34°F) and the freezing potential no longer exists.

2 = Hot Gas Bypass (All Circuits) - Hot gas bypass can stabilize the system balance point by diverting hot, high- pressure refrigerant vapor from the discharge line directly to the low-pressure side of the system. This tactic keeps the compressor more fully loaded while the evaporator satisfies the part-load condition. The Jetson Active Freeze Protection can be configured to function as Hot Gas Bypass by configuring the controller to monitor both the leaving water temperature and the suction temperature. In Hot Gas Bypass operating mode, the Active Freeze Protection provides an additional step of capacity.

Digit 35 — Refrigeration Accessories

0 = Moisture Indicating Sight Glass - The sight glass shows if the liquid line has a full line of liquid or if it has bubbles which shows it's a liquid/vapor mix. It should not be used to determine proper charge. The moisture indicator shows if the system is dry or if it has harmful moisture content.

A = Moisture Indicating Sight Glass + Compressor Isolation Valves – In addition to the Moisture Indicating Sight Glass, ball type Compressor Isolation Valves are mounted on the cooling circuit discharge and liquid lines permitting isolation of the compressors and filter driers for service or replacement. The valves are located close to the compressors. The valve works through a quarter turn from open to closed. Teflon seals and gaskets are used with a nylon cap gasket to prevent accidental loss. This option reduces the amount of refrigerant that must be recovered during compressor service or replacement.

B = Moisture Indicating Sight Glass + Replaceable Core Filter Driers - In addition to the Moisture Indicating Sight Glass, Replaceable Core Filter Driers allow for easy changeout of the filter-drier element.

C = Moisture Indicating Sight Glass + Replaceable Core Filter Driers + Compressor Isolation Valves

Digit 36 — Water Connection

0 = Grooved Pipe Connection, Standard Header Length

A = Grooved Pipe Connection, Extended Header Length – To provide additional spacing beyond the standard ¾” between modules, the Grooved Pipe Connection, Extended Header Length Kit consists of grooved pipe couplings and spacer pipe to allow for easy installation of water manifold units.

D = No Header Piping (Heat Exchangers Only) – When chiller is used in standalone operation (i.e., single module) an array header is not necessary. It is a cost savings to use the 6” array header only when needed for array applications or it is desirable to keep field piping to a minimum. Field piping can be connected to heat exchangers instead of factory provided header.

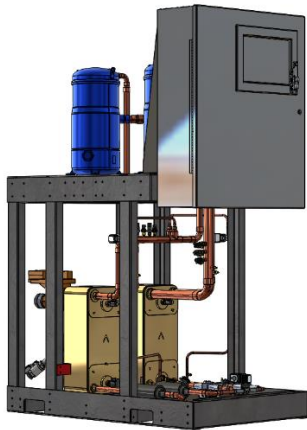

Figure 9 - No Header, Heat Exchangers Only Configuration

Digit 37 — Water Side Pressure

0 = 150 psi

A = 300 psi

Digit 38 — Water Strainer(s)

0 = None

A = Chilled Water Flow Wye Strainer – Factory provided, field installed wye strainer can be placed in a horizontal or vertical pipeline as long as the screen is in a downward position. Straining is accomplished via a 20-mesh lined straining element.

B = Chilled Water Wye Strainer with Installation Kit - Wye strainer installation kits provide piping transitions need to easily attach the wye strainer to the chiller.

C = Condenser Water Flow Wye Strainer – Factory provided, field installed wye strainer can be placed in a horizontal or vertical pipeline as long as the screen is in a downward position. Straining is accomplished via a 20-mesh lined straining element.

D = Condenser Water Wye Strainer with Installation Kit - Wye strainer installation kits provide the piping transitions needed to easily attach the wye strainer to the chiller.

E = Chilled and Condenser Water Nominal Flow Wye Strainer

F = Chilled and Condenser Water Wye Strainer with Installation Kit

Digit 39 — Water Accessories

0 = Chilled Water Flow Switch - An evaporator flow-proving device is required for all FWCD Series chiller applications. A paddle style liquid flow switch is available with a NEMA Type 4X enclosure for field-installation.

B = Analog Water Temperature Gauge - Temperature gauges are factory installed on water lines to indicate water temperature.

C = Analog Water Pressure Gauge - Pressure gauges are factory installed on water lines to indicate pressure drop across heat exchangers.

E = Chilled Water Flow Switch + Analog Water Temperature Gauge

F = Chilled Water Flow Switch + Analog Water Pressure Gauge

J = Chilled Water Flow Switch + Analog Water Temperature Gauge + Analog Water Pressure Gauge

Digit 40 — Blank

0 = Blank

Digit 41 — Sound Attenuator

0 = None

A = Compressor Sound Blankets - Factory installed Compressor Sound Blankets provide insulated sound covers on each compressor. These blankets dampen compressor generated sound. The blankets can be used alone or in combination with a sound cabinet.

B = Factory Sound Enclosure Cabinet - The sound enclosure is a factory installed option. The panels completely encase the chiller module. The panels, lined with sound absorbing insulation, can be removed for access in case of service and provide a streamlined appearance to the product while in place.

C = Compressor Sound Blankets + Factory Sound Enclosure Cabinet

Digit 42 — Unit Mounting

0 = None

A = Neoprene Pads - In applications that are sensitive to noise and vibration, optional neoprene isolator pads can be provided for load bearing points on a FWCD Series modular chiller.

B = Leveling Kit – A height adjustment mechanism located in each corner of the unit to aid in leveling the chiller and to facilitate connections to existing piping.

C = Casters/Wheels - This option is factory-supplied for field installation and includes swivel wheels for easy unit mobility during installation.

D = Neoprene Pads and Casters/Wheels

E = Neoprene Pads and Leveling Kit

Digit 43 — Exterior Finish and Shipping Splits

0 = Standard Paint, Each Module Packaged Separately – Standard Jetson paint is industrial two-part epoxy direct-to-metal paint.

B = Custom Paint, Each Module Packaged Separately – Custom colors are available for applications requiring FWCD Series chiller to match existing color palettes.

Digit 44 — Shipping Options

A = Framed Crate with Plastic Wrap (Non-Shrink)

D = Fully Enclosed Crate

Digit 45 — Warranty

0 = Standard Warranty – Warranty period is a period of twelve (12) months from date of start-up or eighteen (18) months from date of original shipment, whichever may occur first.

A = Five Year Compressor Only Parts Warranty - Additional parts only warranty covering compressor(s) through sixty (60) months from date of shipment.

B = Factory Startup + Owner Training + Two Year Parts & Labor Warranty - Pre-startup unit inspection, startup, and immediate part repair/replacement at the time of startup (if needed) by Modine Service Technicians. Parts and labor warranty period is twenty-four (24) months from date of startup or thirty (30) months from date of original shipment, whichever may occur first. Training includes standard operation and routine maintenance instruction.

C= Factory Startup + Owner Training + Three Year Parts & Labor Warranty - Pre-startup unit inspection, startup, and immediate part repair/replacement at the time of startup (if needed) by Modine Service Technicians. Parts and labor warranty period is thirty-six (36) months from date of startup or forty-two (42) months from date of original shipment, whichever may occur first. Training includes standard operation and routine maintenance instruction.

D= Factory Startup + Owner Training + Four Year Parts & Labor Warranty - Pre-startup unit inspection, startup, and immediate part repair/replacement at the time of startup (if needed) by Modine Service Technicians. Parts and labor warranty period is forty-eight (48) months from date of startup or fifty-four (54) months from date of original shipment, whichever may occur first. Training includes standard operation and routine maintenance instruction.

E= Factory Startup + Owner Training + Five Year Parts & Labor Warranty - Pre-startup unit inspection, startup, and immediate part repair/replacement at the time of startup (if needed) by Modine Service Technicians. Parts and labor warranty period is sixty (60) months from date of startup or sixty-six (66) months from date of original shipment, whichever may occur first. Training includes standard operation and routine maintenance instruction.

F= Factory Startup + Two Year Parts & Labor Warranty - Pre-startup unit inspection, startup, and immediate part repair/replacement at the time of startup (if needed) by Modine Service Technicians. Parts and labor warranty period is twenty-four (24) months from date of startup or thirty (30) months from date of original shipment, whichever may occur first.

G= Factory Startup + Three Year Parts & Labor Warranty - Pre-startup unit inspection, startup, and immediate part repair/replacement at the time of startup (if needed) by Modine Service Technicians. Parts and labor warranty period is thirty-six (36) months from date of startup or forty-two (42) months from date of original shipment, whichever may occur first.

H= Factory Startup + Four Year Parts & Labor Warranty- Pre-startup unit inspection, startup, and immediate part repair/replacement at the time of startup (if needed) by Modine Service Technicians. Parts and labor warranty period is forty-eight (48) months from date of startup or fifty-four (54) months from date of original shipment, whichever may occur first.

J= Factory Startup + Five Year Parts & Labor Warranty - Pre-startup unit inspection, startup, and immediate part repair/replacement at the time of startup (if needed) by Modine Service Technicians. Parts and labor warranty period is sixty (60) months from date of startup or sixty-six (66) months from date of original shipment, whichever may occur first.

K= Factory Startup + First Year Labor Only Warranty - Pre-startup unit inspection, startup, and immediate part repair/replacement at the time of startup (if needed) by Modine Service Technicians. Parts and labor warranty period is twelve (12) months from date of startup or eighteen (18) months from date of original shipment, whichever may occur first.

L= Factory Startup + Owner Training + First Year Labor Only Warranty - Pre-startup unit inspection, startup, and immediate part repair/replacement at the time of startup (if needed) by Modine Service Technicians. Parts and labor warranty period is twelve (12) months from date of startup or eighteen (18) months from date of original shipment, whichever may occur first. Training includes standard operation and routine maintenance instruction.

M= Factory Startup + Owner Training + Two Year Parts Only Warranty - Pre-startup unit inspection, startup, and immediate part repair/replacement at the time of startup (if needed) by Modine Service Technicians. Parts warranty period is twenty-four (24) months from date of startup or thirty (30) months from date of original shipment, whichever may occur first. Training includes standard operation and routine maintenance instruction.

N= Factory Startup + Owner Training + Three Year Parts Only Warranty - Pre-startup unit inspection, startup, and immediate part repair/replacement at the time of startup (if needed) by Modine Service Technicians. Parts warranty period is thirty-six (36) months from date of startup or forty-two (42) months from date of original shipment, whichever may occur first. Training includes standard operation and routine maintenance instruction.

P= Factory Startup + Owner Training + Five Year Parts Only Warranty - Pre-startup unit inspection, startup, and immediate part repair/replacement at the time of startup (if needed) by Modine Service Technicians. Parts warranty period is sixty (60) months from date of startup or sixty-six (66) months from date of original shipment, whichever may occur first. Training includes standard operation and routine maintenance instruction.

Q= Factory Startup + Two Year Parts Only Warranty - Pre-startup unit inspection, startup, and immediate part repair/replacement at the time of startup (if needed) by Modine Service Technicians. Parts warranty period is twenty-four (24) months from date of startup or thirty (30) months from date of original shipment, whichever may occur first.

R= Factory Startup + Three Year Parts Only Warranty - Pre-startup unit inspection, startup, and immediate part repair/replacement at the time of startup (if needed) by Modine Service Technicians. Parts warranty period is thirty-six (36) months from date of startup or forty-two (42) months from date of original shipment, whichever may occur first.

S= Factory Startup + Five Year Parts Only Warranty - Pre-startup unit inspection, startup, and immediate part repair/replacement at the time of startup (if needed) by Modine Service Technicians. Parts warranty period is sixty (60) months from date of startup or sixty-six (66) months from date of original shipment, whichever may occur first.

T= Factory Startup + Five Year Compressor Only Parts Warranty (AC) - Pre-startup unit inspection, startup, and immediate part repair/replacement at the time of startup (if needed) by Modine Service Technicians. Additional parts only warranty covering compressor(s) through sixty (60) months from date of shipment.

U= Factory Startup + Owner Training + Five Year Compressor Only Parts Warranty (AC) - Pre-startup unit inspection, startup, and immediate part repair/replacement at the time of startup (if needed) by Modine Service Technicians. Additional parts only warranty covering compressor(s) through sixty (60) months from date of shipment. Training includes standard operation and routine maintenance instruction.

V= Factory Startup Service + 1 Year Parts Only Warranty - Pre-startup unit inspection, startup, and immediate part repair/replacement at the time of startup (if needed) by Modine Service Technicians. All parts warranty period is twelve (12) months from date of startup or eighteen (18) months from date of original shipment, whichever may occur first.

W= Factory Startup Service w/Owner Training + 1 Year Parts Only Warranty - Pre-startup unit inspection, startup, and immediate part repair/replacement at the time of startup (if needed) by Modine Service Technicians. All parts warranty period is twelve (12) months from date of startup or eighteen (18) months from date of original shipment, whichever may occur first. Training includes standard operation and routine maintenance instruction. Training includes standard operation and routine maintenance instruction.

X= Two Year Parts Only Warranty - Additional parts only warranty covering all parts through twenty-four (24) months from date of shipment.

Y= Three Year Parts Only Warranty - Additional parts only warranty covering all parts through thirty-six (36) months from date of shipment.

Z= Five Year Parts Only Warranty - Additional parts only warranty covering all parts through sixty (60) months from date of shipment.

Digit 46 — Special Options

0 = None

X = With Specials

General Data

Table 11 - General Unit Information

	Unit Size (Nominal Tons)						
	20	30	45	55	65	75	85
Compressors							
Compressor - Quantity/Nominal Size (Tons)	2 / 10	2 / 15	2 / 20	2 / 25	2 / 30	1 / 30, 1/40	2 / 40
Capacity Steps	2						
Compressor Sound Data (dbA)	81	84	88	89	92	93	94
Compressor Sound Data with Sound Blankets Only (dbA)	75	78	84	85	88	89	90
Number of Circuits	1 or 2					2	
Evaporator							
<u>Standard – Brazed Plate: Quantity</u>	1						
Connection Size (Inch)	2 ½						
Max GPM	72	108	162	198	234	270	306
Min GPM	24	36	54	66	78	90	102
<u>Optional - Oversize Brazed Plate</u>							
<u>Quantity</u>	1						
Connection Size (Inch)	2 ½						
Max GPM	72	108	162	198	234	270	NA
Min GPM	24	36	54	66	78	90	NA
Max Water Pressure (psig)	300						
Condenser							
<u>Brazed Plate: Quantity</u>	1						
Connection Size (Inch)	2 ½						
Max GPM	90	135	202	246	292	337	382
Min GPM	30	45	67	82	97	112	127
Max Water Pressure (psig)	300						
<u>Shell and Tube: Quantity</u>							
<u>Quantity</u>	1						
Connection Size (Inch)	2 ½	2 ½	3	3	4	4	NA
Max GPM	150	150	245	245	250	250	NA
Min GPM	35	35	60	60	85	85	NA
Max Water Pressure (psig)	250						

Pressure Drop Curves

Figure 10- Evaporator Flow (heat exchanger only) vs. Pressure Drop

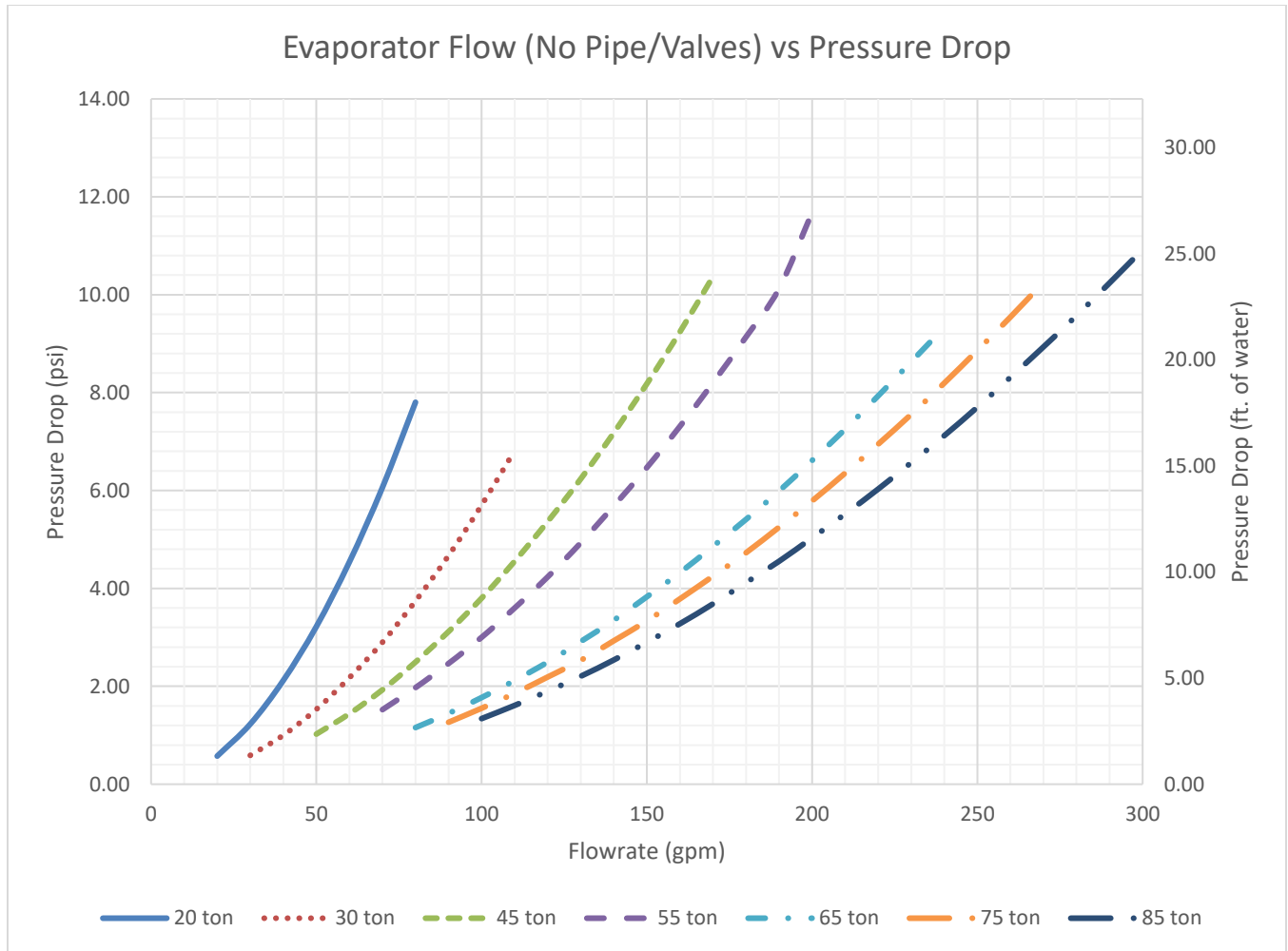

Figure 11- Brazed Plate Condenser Flow (heat exchanger only) vs. Pressure Drop

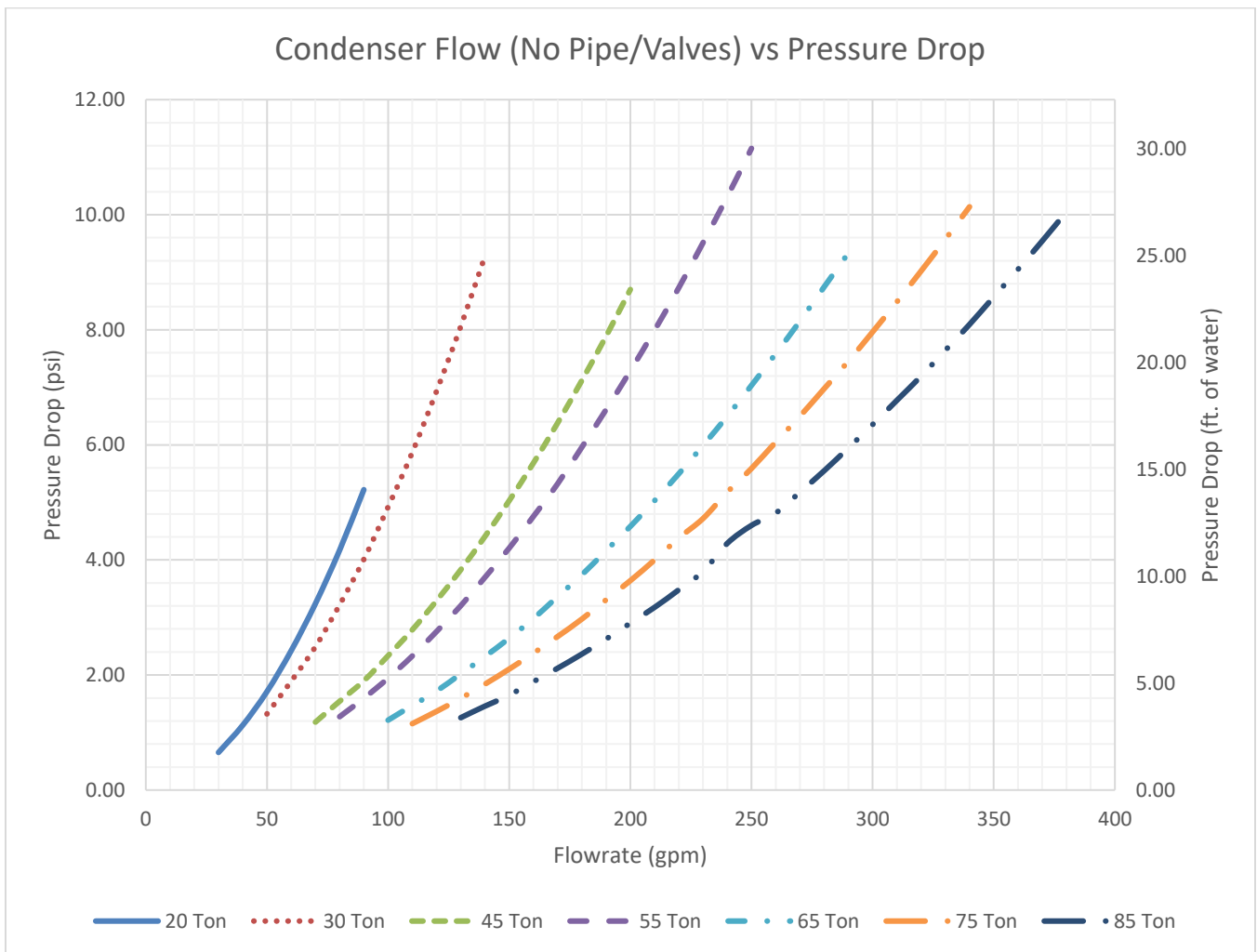
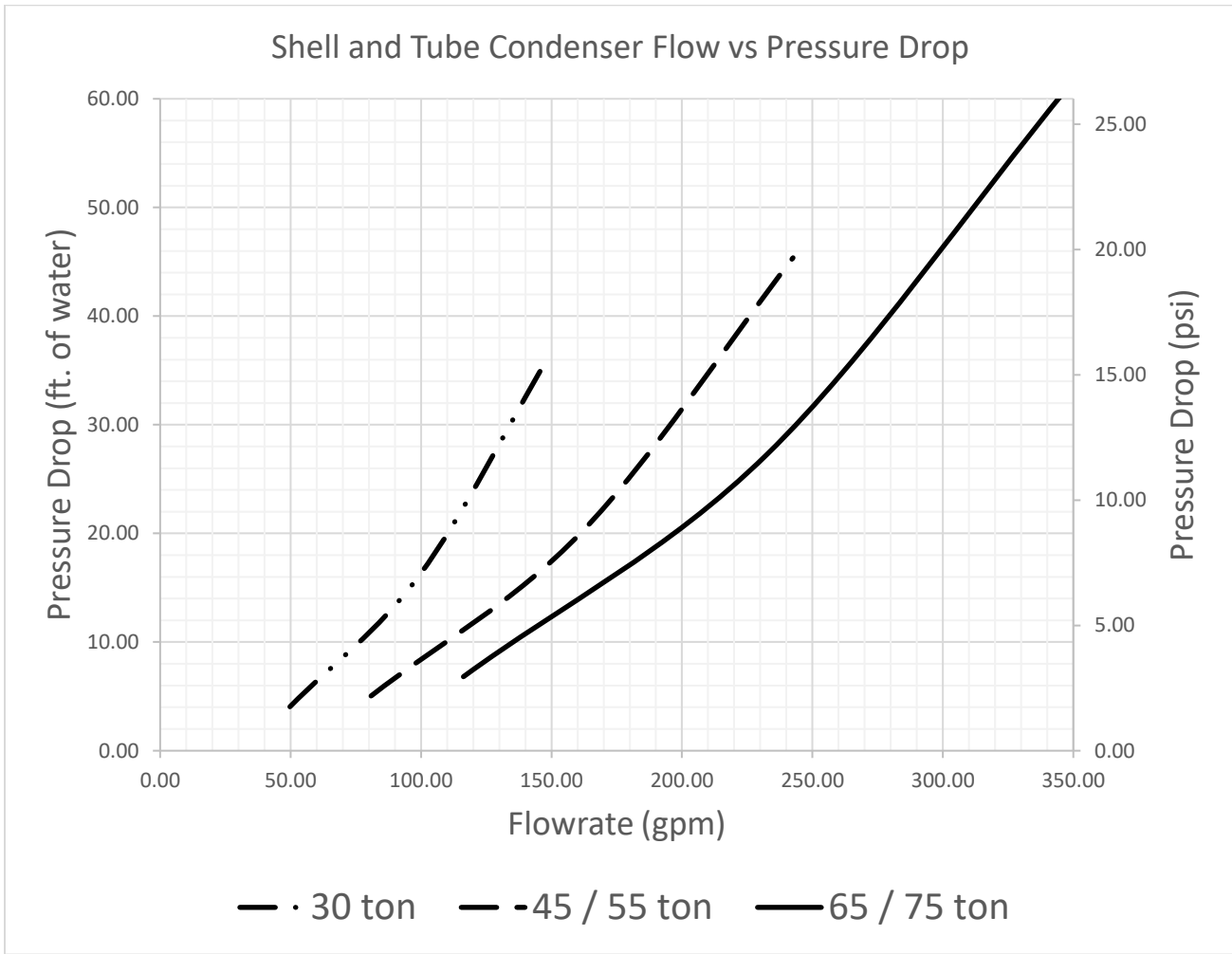

Figure 12- Shell and Tube Flow (including header and valves) vs. Approximate Pressure Drop



Electrical Service Sizing Data

Use the following table to correctly size the electrical service wiring for the unit(s). Information does not cover variable speed compressors.

Table 12- FWCD Electrical Data

Unit Size	Voltage	Comp #1 MCC	Comp #2 MCC	Comp #1 LRA	Comp #2 LRA	Comp #1 RLA	Comp #2 RLA	Unit MCA	Unit Max Fuse	Unit Rec. Fuse
20	200-230/3/60	61	61	267	267	39.10	39.10	88	125	100
	460/3/60	29	29	142	142	18.59	18.59	42	60	50
	575/3/60	24	24	103	103	15.38	15.38	35	50	40
30	200-230/3/60	75	75	351	351	48.08	48.08	108	150	125
	460/3/60	39	39	197	197	24.74	24.74	56	80	60
	575/3/60	35	35	135	135	22.44	22.44	51	70	60
45	200-230/3/60	105	105	485	485	67.31	67.31	151	200	175
	460/3/60	51	51	215	215	32.69	32.69	74	100	80
	575/3/60	41	41	175	175	26.28	26.28	59	80	70
55	200-230/3/60	128	128	560	560	82.05	82.05	185	250	225
	460/3/60	62	62	260	260	39.74	39.74	89	125	100
	575/3/60	45	45	210	210	28.85	28.85	65	90	70
65	200-230/3/60	170	170	717	717	108.97	108.97	245	350	250
	460/3/60	79	79	320	320	50.64	50.64	114	150	125
	575/3/60	60	60	235	235	38.46	38.46	87	125	100
75	208/230/3/60	170	190	717	1010	108.97	121.79	261	350	300
	460/3/60	79	106	320	344	50.64	67.95	136	200	150
	575/3/60	60	71	235	327	38.46	45.51	95	125	110
85	208/230/3/60	190	190	1010	1010	121.79	121.79	274	350	300
	460/3/60	106	106	344	344	67.95	67.95	153	200	175
	575/3/60	71	71	327	327	45.51	45.51	102	125	125

To size a field supplied distribution panel for an array of chillers, use the following steps.

1. The Max Fuse or Maximum Overcurrent Protection Device (MOCP) of the electrical distribution panel is as follows:

- a. To find the MOCP of the electrical distribution panel associated with a bank of chillers follow these steps:
 1. Find the component with the Largest RLA (usually the largest compressor of all of the chillers).
 2. Calculate MOCP using this formula: $MOCP = (2.25 \times \text{Largest RLA}) + \text{sum of all of the other RLAs}$. Select the next size down fuse from this value.

Standard Ampere Ratings for Fuses (From NEC Handbook, 240-6)

The standard ratings for fuses shall be considered 15, 20, 25, 30, 35, 40, 45, 50, 60, 70, 80, 90, 100, 110, 125, 150, 175, 200, 225, 250, 300, 350, 400, 450, 500, 600, 700, 800, 1000, 1200, 1600, 2000, 2500, 3000 and 4000 amperes.

2. **The recommended fuse size in amps (RFA) is calculated as follows:**
 - a. $RFA = 1.75 * (\text{largest RLA}) + (\text{Smallest RLA})$ for the given bank of chillers.
3. **The MCA of the electrical distribution panel is calculated as follows:**
 - a. To find the MCA of the electrical distribution panel associated with a bank of chillers follow these steps:
 - i. Find the component with the Largest RLA (usually the largest compressor of all of the chillers).
 - ii. Calculate MCA using this formula: $MCA = (1.25 \times \text{Largest RLA}) + \text{sum of all of the other RLAs}$.
4. **Wiring for main field supply must be copper conductor and rated 75 C.**

Array Single Point Power Distribution Panel Size

Figure 12- Single Point Power Distribution Panel Estimated Dimensions

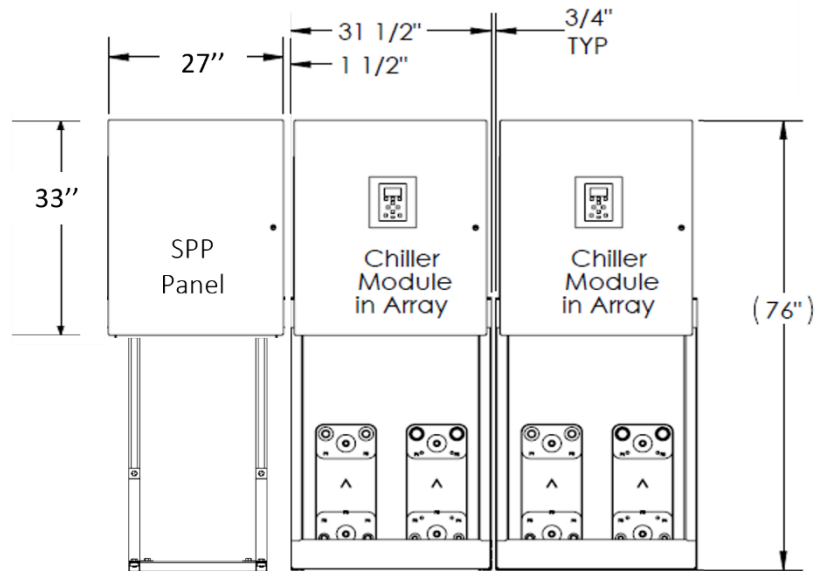

Note:

- Total array ampacity may not exceed 1200 amps when using a single power distribution panel
- Estimated dimensions

Weights and Dimensions

Table 13- FWCD unit weights

Size	Shipping Weight						Operating Weight					
	Braze Plate Condenser		Shell-and-Tube Condenser		Remote Condenser		Braze Plate Condenser		Shell-and-Tube Condenser		Remote Condenser	
	ton	lbs.	kg	lbs.	kg	lbs.	kg	lbs.	kg	lbs.	kg	lbs.
20	1326	601	1467	665	1069	485	1525	692	1688	766	1168	530
30	1495	678	1760	798	1205	547	1720	780	2025	919	1320	599
45	1775	805	1970	894	1420	644	2040	925	2265	1027	1550	703
55	1795	814	1970	894	1410	639	2065	937	2265	1027	1545	701
65	2230	1012	2640	1197	1770	803	2565	1163	3035	1377	1940	880
75	2235	1014	2640	1197	1775	805	2570	1166	3035	1377	1945	882
85	2487	1128	2925	1327	1963	890	2860	1297	3362	1525	2152	976

Figure 14 – Recommended Service Clearances

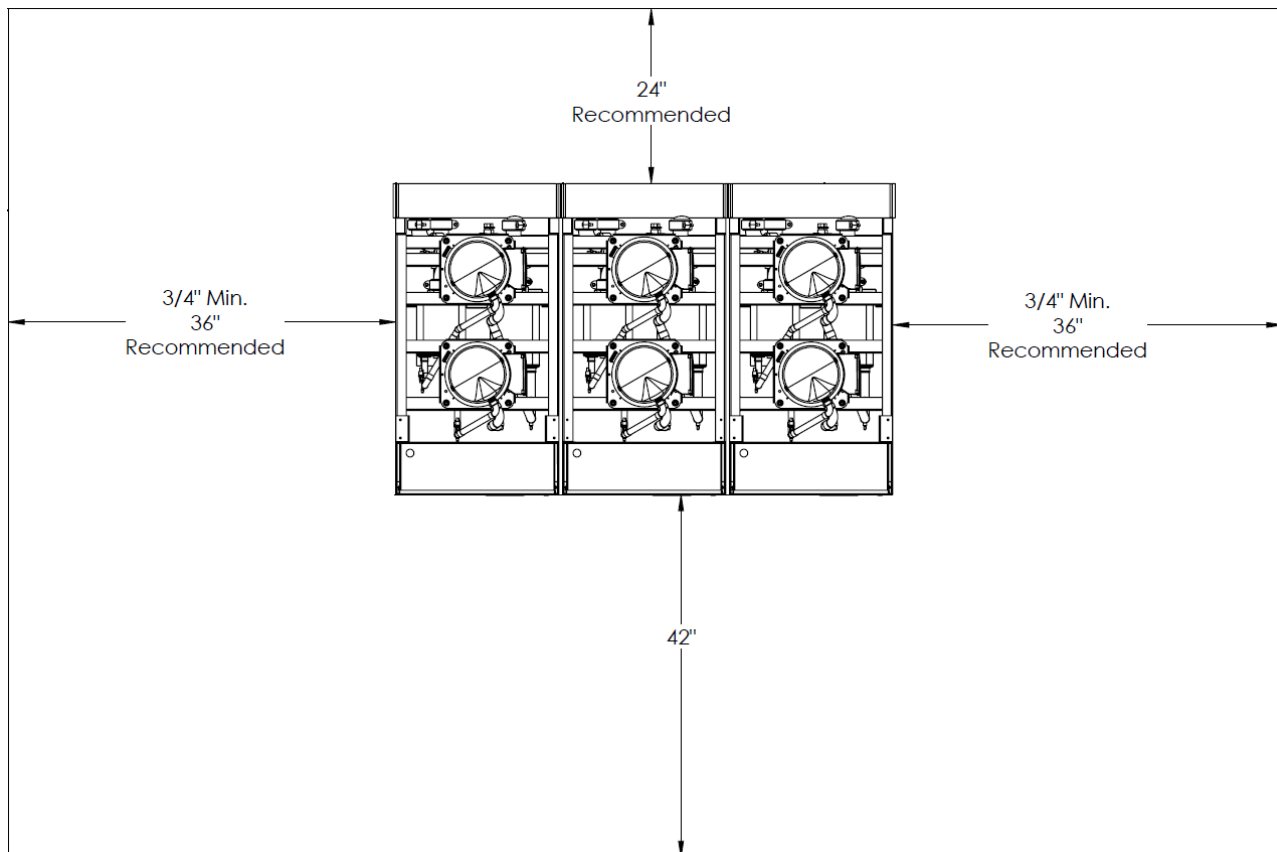

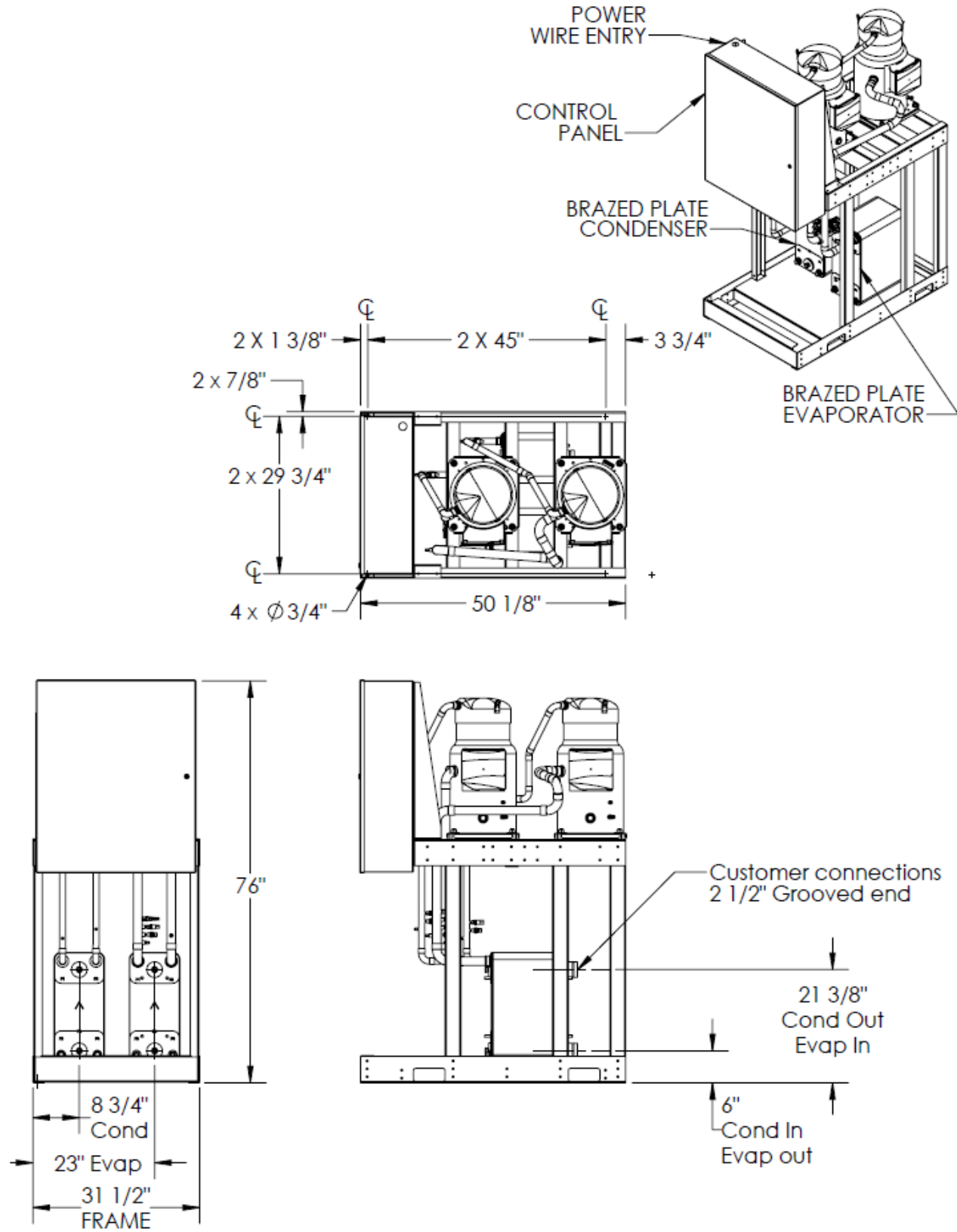

Figure 15 - No Header Piping, Brazed Plate Condenser (Standalone Chiller Application)

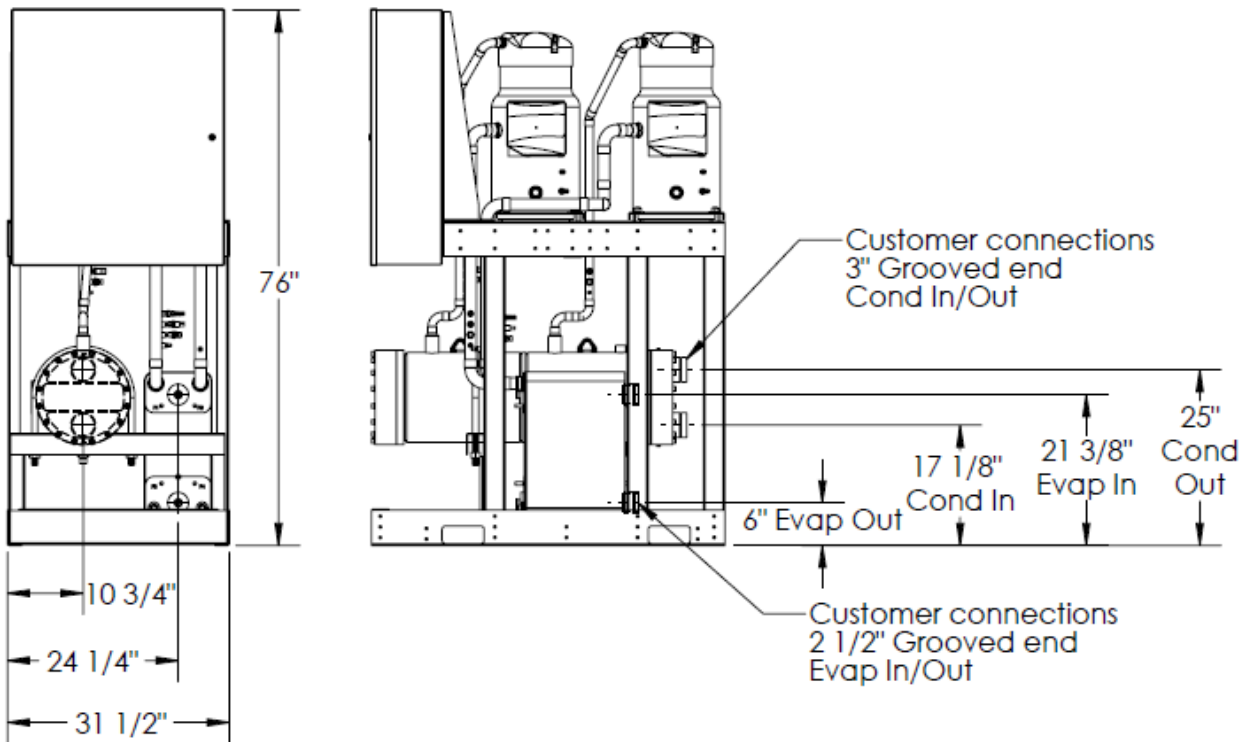
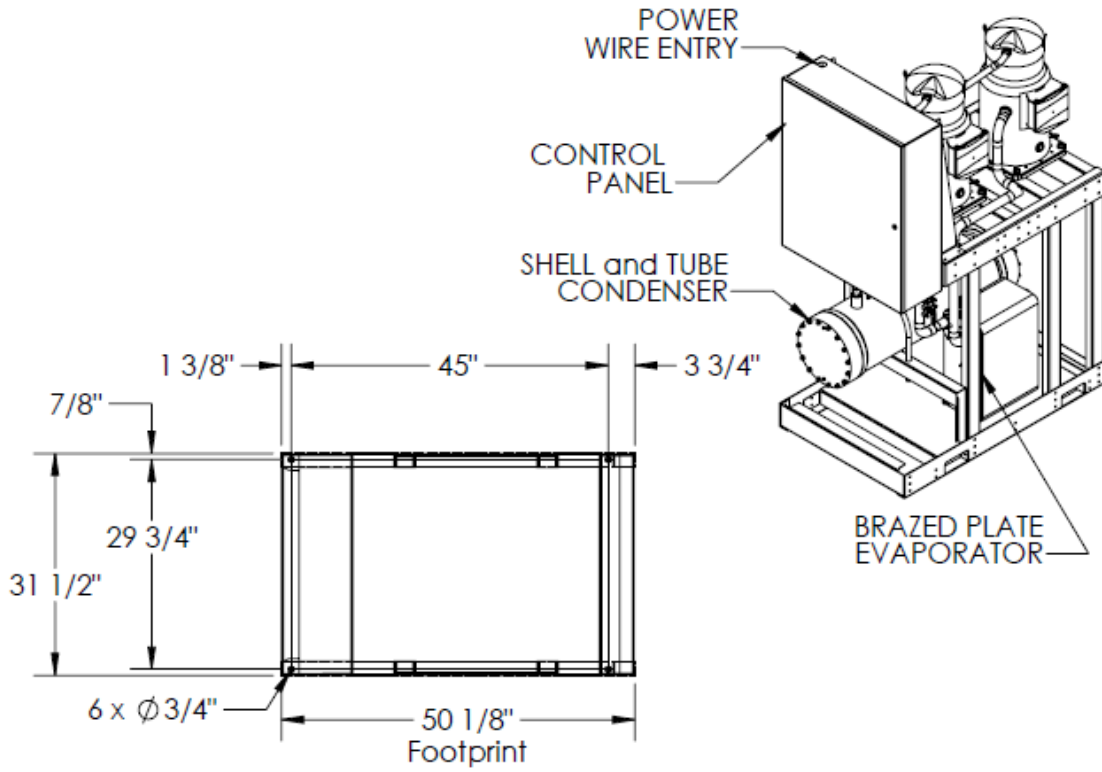

Figure 16 - No Header Piping, Shell & Tube Condenser (Standalone Chiller Application)

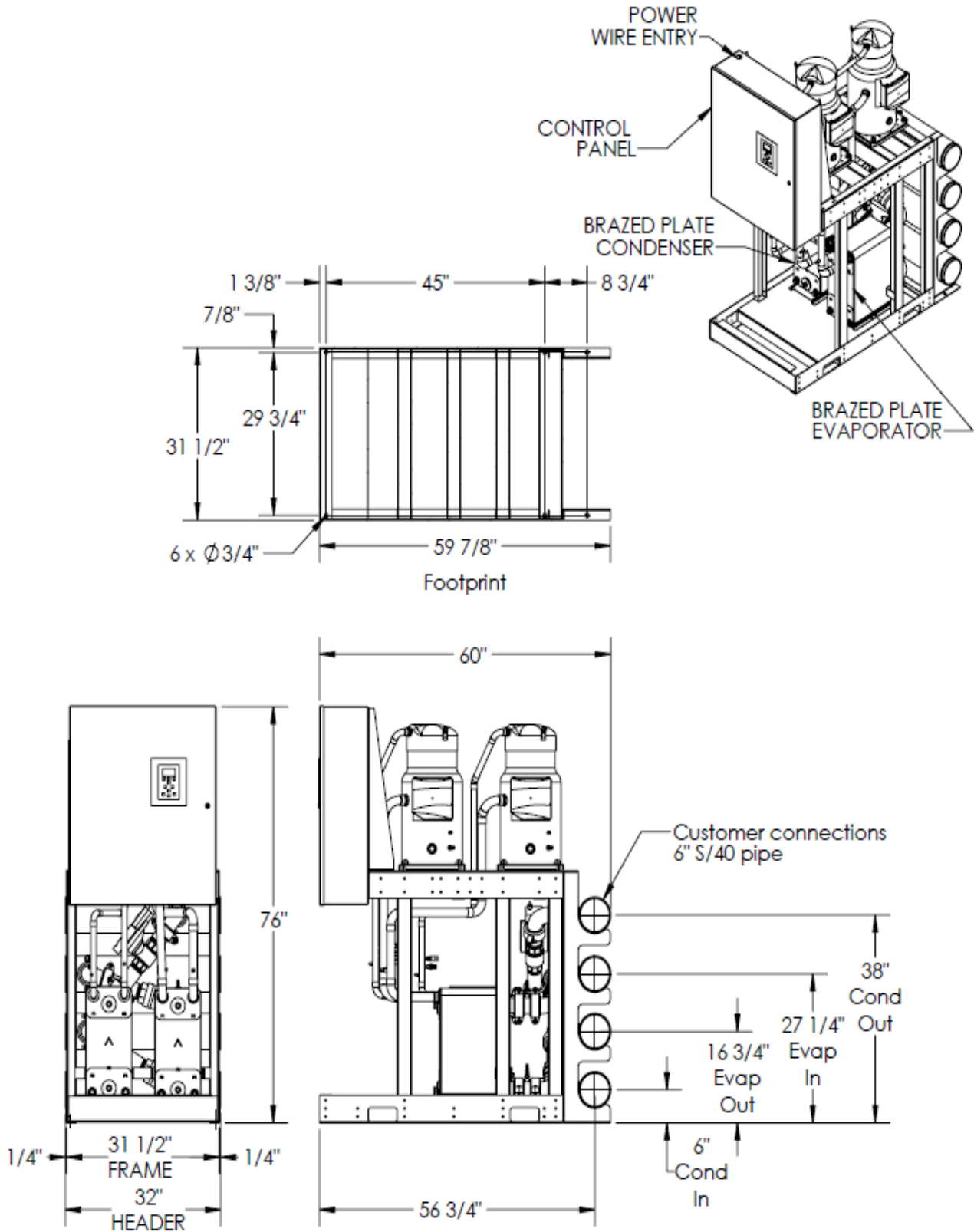

Figure 17 - Header Piping, Brazed Plate Condenser (Array application)

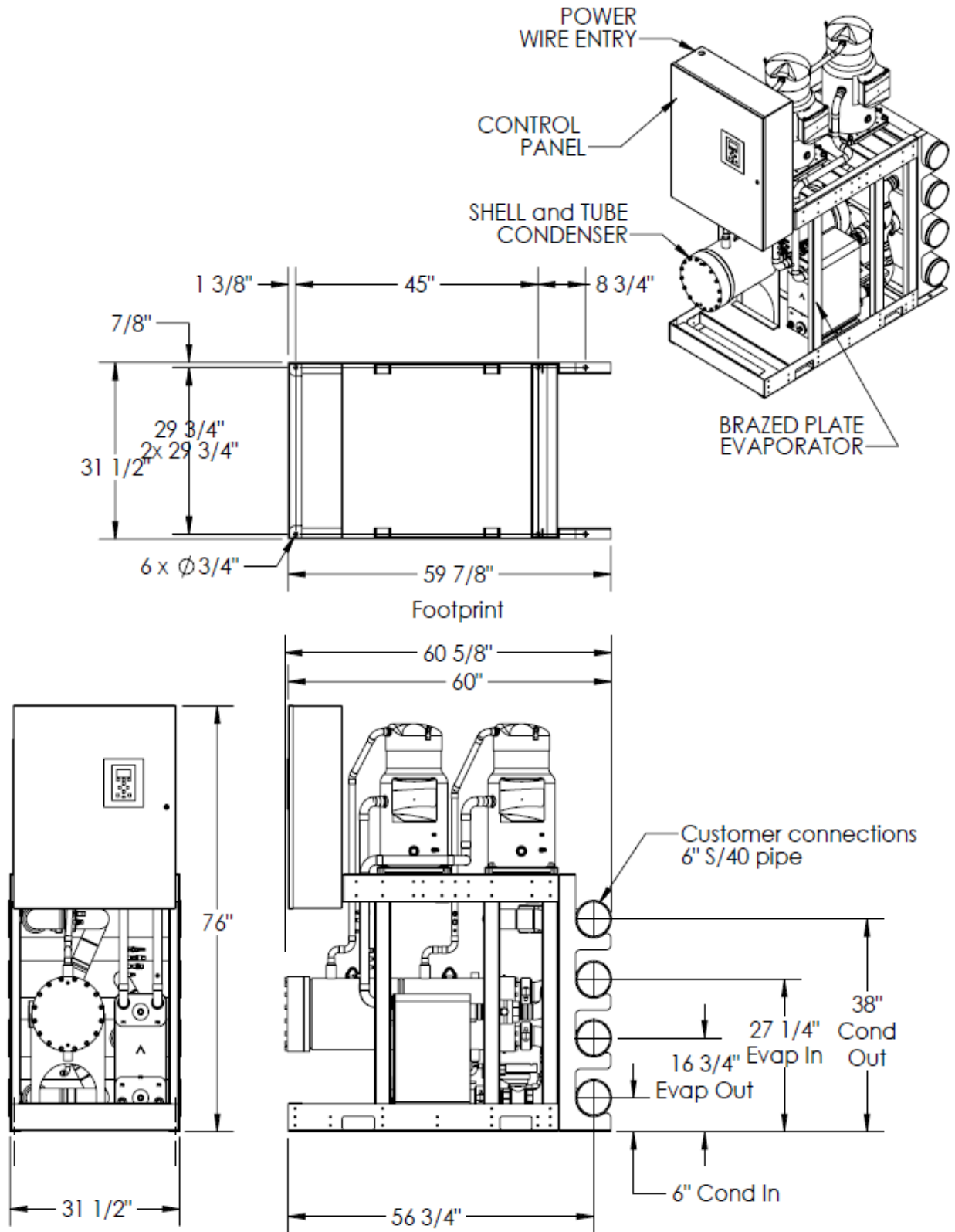

Figure 18 - Shell and Tube Condenser (Array application)

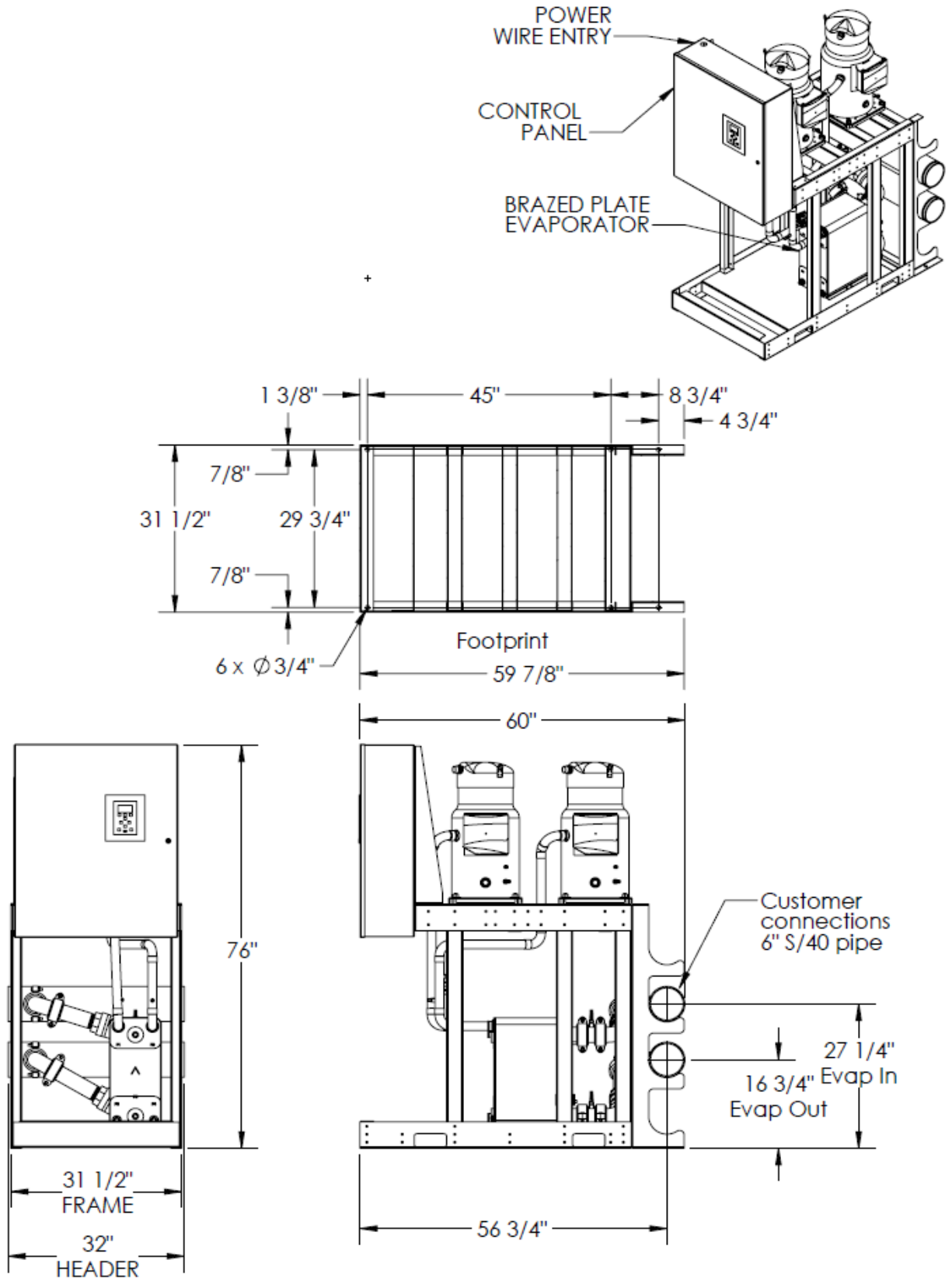

Figure 19 - Remote Air-Cooled Condenser (Array application)

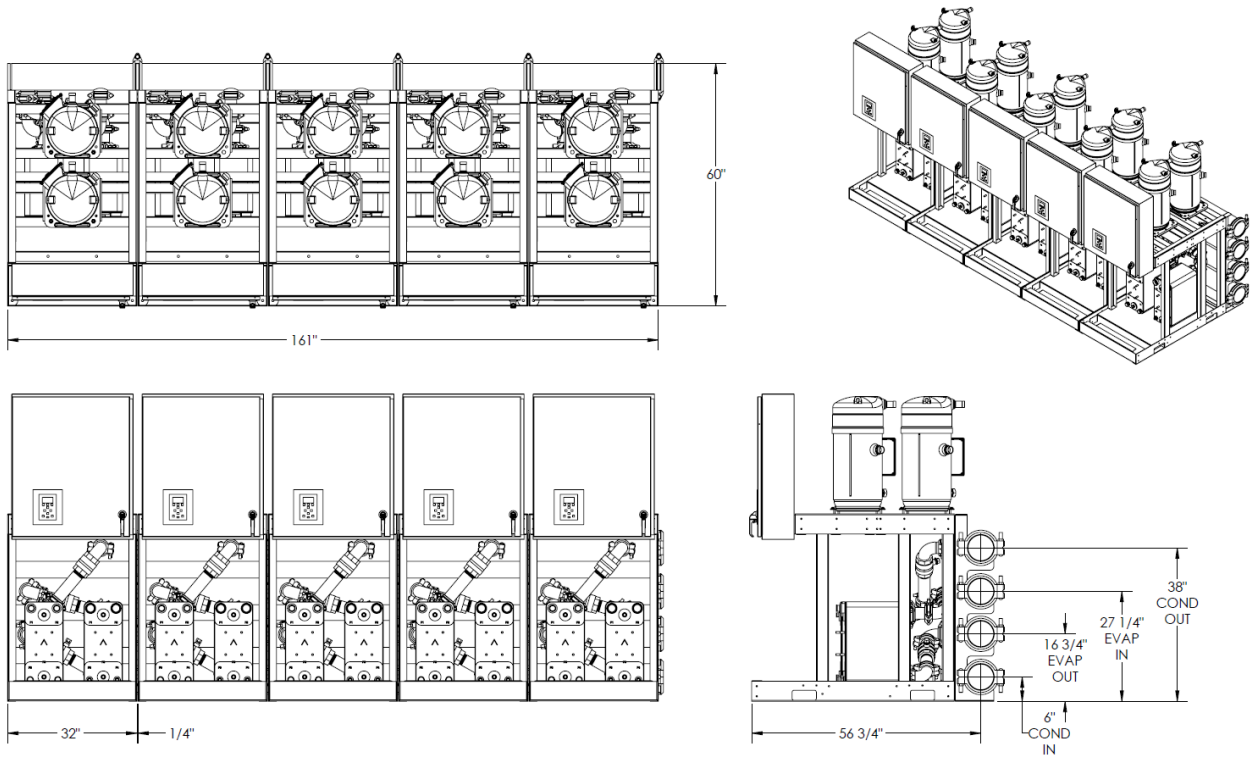

Figure 20 - Example Array Dimensions

LITERATURE CHANGE HISTORY

11/12/2019 – Updated line sizes for remote air-cooled application

11/14/2019 – Updated General Data Table connection sizes for shell and tube condenser.

11/27/2019 – Updated electrical values (MCA, MOP, Fuse) for 75 ton

06/02/2020 – Updated to include 85-ton module. Updated refrigerant line sizes.

09/27/2021 – Adjusted maximum and minimum flows for condensers and evaporators in general data tables.

09/28/2021 – Increased discharge line velocities recommended in text and removed Table 6: Recommended discharge line velocities. Adjusting controller name from Master-Slave to Master-Secondary.

01/03/2022 – Expanded variable flow text.

01/05/2022 – Updated evaporator and condenser control valve digits

01/28/2022 – Corrected text referring to ACC chillers

02/16/2022 – Corrected text referring to buffer tank location

02/15/2023 – Updated cover picture

07/31/2023 – Update 75ton, 460V unit max fuse from 175 to 200 amp. Updated text for calculating array MOP and MCA for distribution panels.

07/31/2023 – Added additional pressure drop charts for “heat exchanger” only. Updated charts with heat exchanger and valves/piping.

04/23/2024: Updated cover picture. R-454B data added to the catalog. Optional building communication protocols updated.

04/26/2024: Adjusted maximum and minimum flows for condensers and evaporators in general data tables.

04/29/2024: R-410A unit selection procedure, performance data and correction factors removed.

04/30/2024: R-410A digit options removed. Digit 10 and 39 options revised. Revised line sizing for R-454B split applications.

05/06/2024: Updated digit 45 -warranty options. Updated Array Single Point Panel Size. Updated pressure drop charts.

05/07/2024: JET17-101 literature number added.

08/09/2024: Updated table 7

08/14/2024: Updated line sizing guidelines adding the Table 6 as minimum discharge velocities for oil entrainment.



**905 W. Cotton Street
Longview, TX 75604
Phone: 903-758-2900
www.JetsonHVAC.com**

**Product Catalog FWCD Series
Revision 240814
JET17-101**

It is the intent of Jetson to provide accurate up-to-date specification data. However, in the interest of ongoing product improvement, Jetson by Modine reserves the right to change specifications and/or design of any product without notice, obligation, or liability.