

**AIR-TO-
WATER HEAT
PUMPS
BY**

Jetson
Excellence in HVAC

Air-to-Water Heat Pump Systems

Air-to-water heat pump units are air-source refrigeration units with the ability to produce chilled or heated fluid with one refrigerant-to-water heat exchanger. A refrigerant reversing valve is used to switch between cooling and heating modes.

Air-to-water heat pumps (AWHPs) are an emerging equipment category driven out of a desire to decarbonize HVAC systems through electrified heating solutions. Heat pump technology offers coefficients of performance (COP) far exceeding resistance-based heating thus enabling a reduced heating energy intensity.

Jetson offers the ACC air-to-water heat pump, a packaged unit based on a commercial air-cooled chiller. The ACC is available in a range of 10 to 90 tons of nominal cooling capacity and can be configured in a modular array to provide up to 800 tons of cooling. The ACC can deliver up to 140°F fluid temperature and is capable of heating operation down to 0°F outdoor air temperature.

Understanding Air-to-Water Heat Pump Units

There are various AWHP unit configurations including: two- and four-pipe units and units with heat recovery.

It is important to note that an AWHP unit capacity and efficiency can vary significantly depending on the outdoor air temperature and desired leaving fluid temperature. This is particularly true in the heating mode where the operating capacity at a low outdoor temperature (i.e., 0°F) may be 50 percent lower than at a moderate outdoor temperature (i.e., 47°F). The loss of capacity is a normal result of the reduction in refrigerant gas density at low suction temperatures. For that reason, it is critical to select system capacity based on actual operating conditions, not code related performance rating points.

Two-pipe units

Two-pipe AWHP units have one refrigerant-to-water heat exchanger that can cool or heat, but not both simultaneously. Two-pipe units have one pipe for supply of fluid and one pipe for return of the same fluid. At any given time, the units operate in only one mode—either heating or cooling—and use outdoor air as the source or sink to provide heating or cooling fluid. The unit changes between either cooling or heating modes of operation. Changeover between heating and cooling (heat pump) is commanded by a building management system (BMS), or operator, and is accomplished in the unit via onboard controls.

The refrigeration component that enables changeover between the cooling and heating modes of operation is a refrigerant reversing valve (four-way valve). A reversing valve switches the flow of refrigerant through the heat exchangers depending on the unit mode of operation (heating or cooling). As shown in Figure 1. Reversing (four-way) valve, the refrigerant always flows through the compressor in the same direction. The reversing valve coordinates flow direction through the outdoor coil/heat exchanger (refrigerant-to-air) and the braze plate (refrigerant-to-water) heat exchangers in the unit.

Figure 1. Reversing (four-way) valve

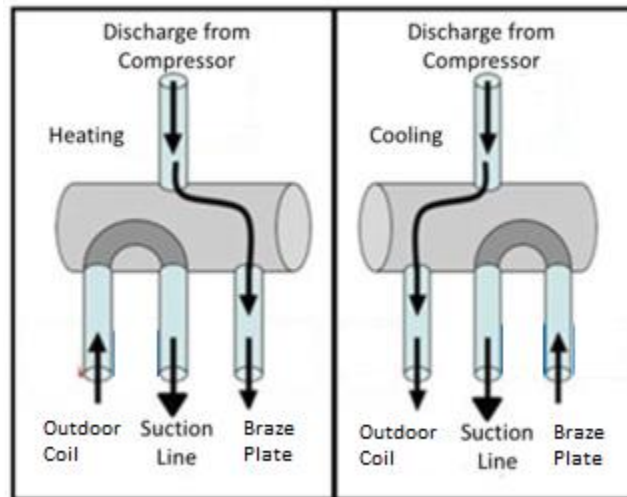

AWHP units are applied in systems in two different manners.

- Changeover cooling/heating: This is the most common application. The AWHP units provide either heating or cooling and changeover between the two modes depending on the load demands of the building and as commanded by the building management system.
- Dedicated heating only: The unit runs primarily in the heat mode as cooling mode operation is not required. However, at outdoor air temperatures below 47°F the unit may initiate defrost cycles which cool the fluid for short periods of time. Again, the building management system commands the unit to operate in heating as required by the system served by the heat pump.

Two-Pipe AWHP unit modes of operation

Two-pipe AWHPs can operate in three modes: cooling mode, heating mode, and defrost mode. Figure 2, Figure 3, and Figure 4 show the refrigeration circuit operation in each mode including the respective heat source and sink in each mode.

1. **Cooling Mode** – As shown in Figure 2, the refrigerant-to-water heat exchanger is the energy source for the refrigeration circuit, absorbing heat from the chilled water. The refrigerant-to-air coil is the energy sink, rejecting heat to ambient air. In this mode, the machine has the same operation as an air-cooled chiller.

Figure 2. Cooling Mode Operation

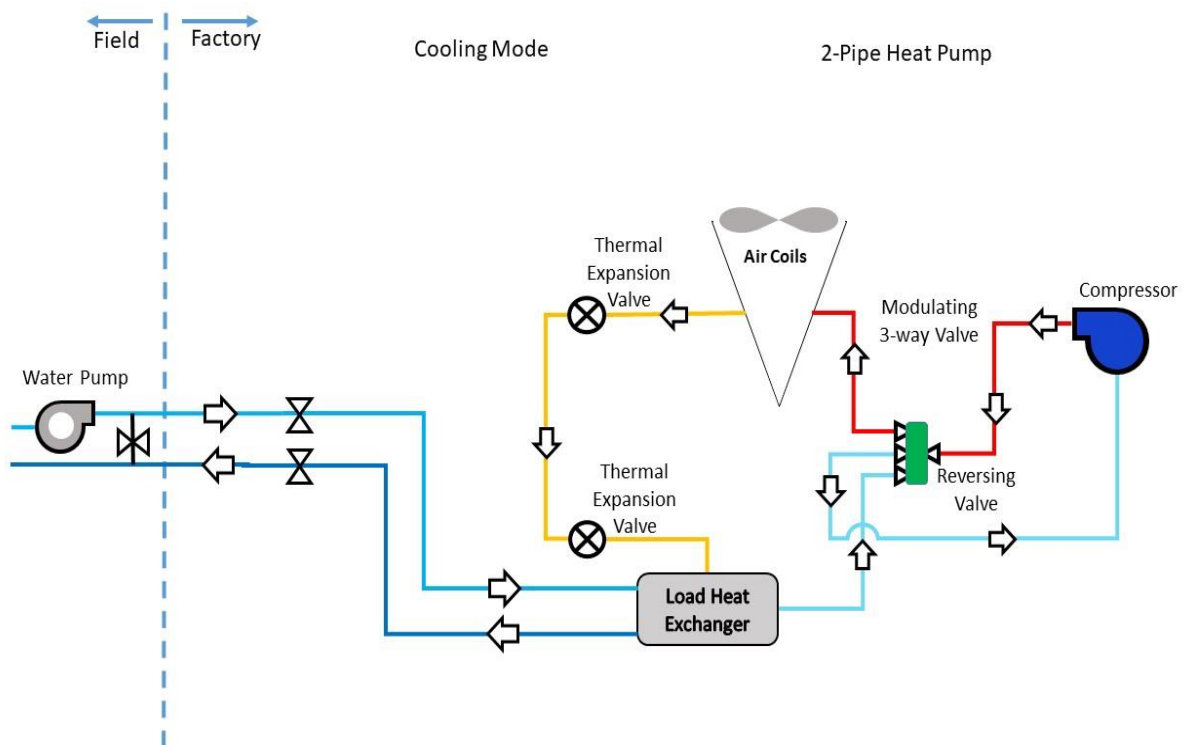

2. **Heating Mode** – As shown in Figure 3, the refrigerant-to-air heat exchanger is the energy source in the circuit, absorbing heat from the outdoor air, while the refrigerant-to-water is the energy sink in the circuit, rejecting heat to the heating water circuit.

Figure 3. Heating Mode Operation

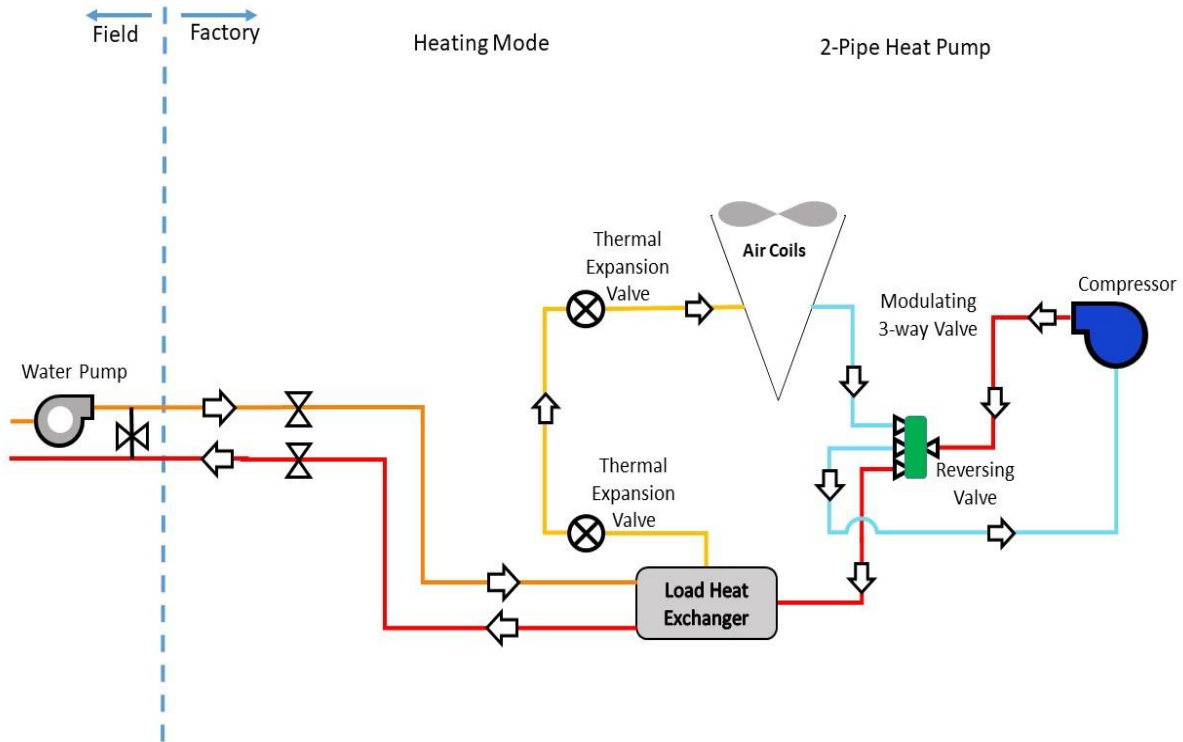

- Defrost Cycle** –Figure 4 shows the refrigeration circuit is in the cooling mode supplying heat to melt accumulated ice from the refrigerant-to-air heat exchanger. The return heating water is the source for the heat energy needed to defrost the outdoor air coil. The heat energy for defrost is extracted from the heating water loop.

Figure 4. Defrost Cycle Operation

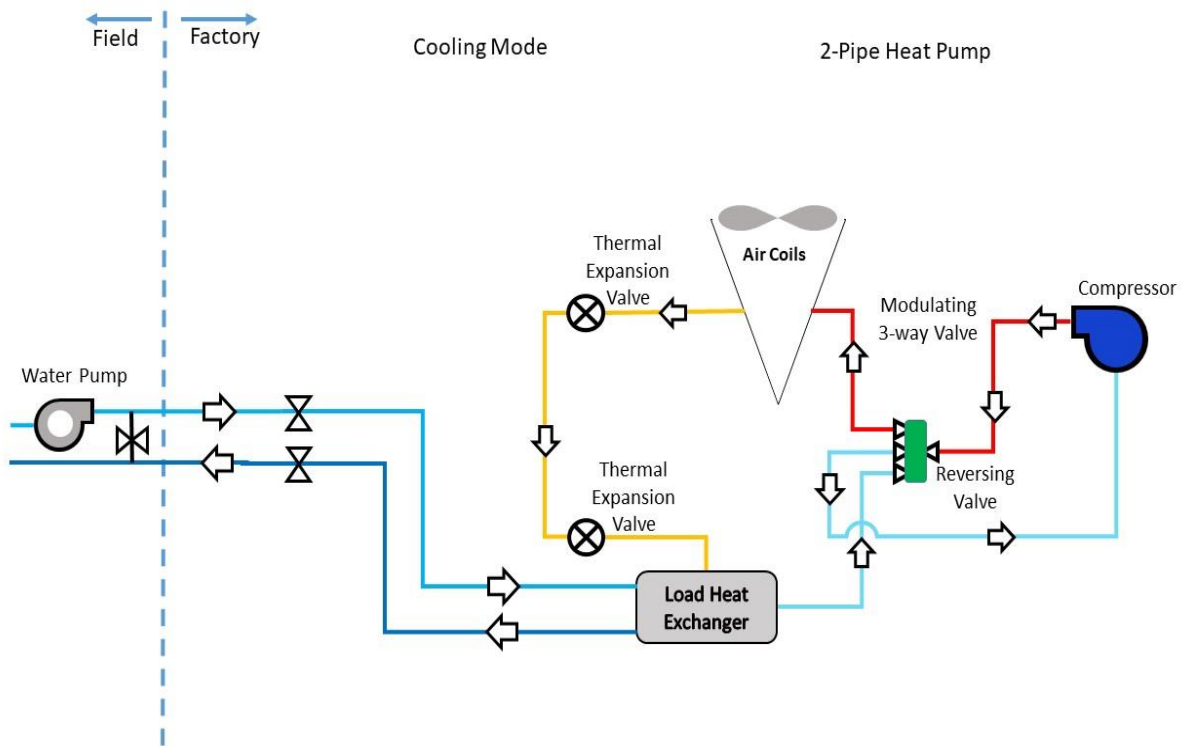

Four-pipe heat recovery units

These units have one load refrigerant-to-water heat exchanger that can cool or heat, but not both simultaneously. In addition to the load heat exchanger, there is a second refrigerant-to-water heat exchanger that can heat a separate fluid loop, when the load refrigerant-to-water heat exchanger is in cooling operation, as shown in Figure 5. The second heat exchanger allows for a form of heat recovery; instead of the machine rejecting heat, removed from the cooling loop, to the ambient air, the heat is instead repurposed in a useful manner to heat a separate fluid loop.

Figure 5. Four Pipe Heat Pump with Heat Recovery



Four-Pipe AWHP unit modes of operation

Four-pipe AWHPs can operate in four modes: heat recovery mode, heating mode, cooling mode, and defrost mode.

Figure 6, Figure 7, Figure 8 and Figure 9 show the refrigeration circuit operation in each mode including the respective heat source and load in each mode.

1. **Heat recovery mode** – Heat recovery can only be used when there is a simultaneous cooling load. The cooling setpoint is controlled by compressor capacity. As more cooling is needed, additional compressor capacity is activated. As less cooling is needed, less compressor capacity is activated.

The hot water setpoint is controlled by the modulating hot gas valve. As more heating is needed, the modulating hot gas valve sends more hot gas to the heat recovery condenser. As less heating is needed, the modulating hot gas valve sends less hot gas to the heat recovery condenser and more hot gas is sent to the air-to-refrigerant heat exchanger to be rejected to ambient air.

The amount of heat recovery available is usually 10-20% more than the cooling load being satisfied, at the same time. This is because the heat absorbed from the cooling loop and the inefficiencies of compression and compressor motor work are added to the refrigerant loop as heat and are available for heat recovery. For example, a 60-ton chiller is running 50% loaded; producing 30 tons of cooling; the heat recovery capacity will be approximately 34.5 tons (1.15×30 tons) or 414 mBh. When the same machine is running fully loaded and producing 60 tons of cooling, the heat available for heat recovery will be 69 tons (1.15×60 tons) or 828 mBh.

During heat recovery mode, the chilled water and heat recovery water valves are open, while the load heat exchanger hot water valves are closed.

Figure 6. Four-Pipe Heat Recovery Mode Operation

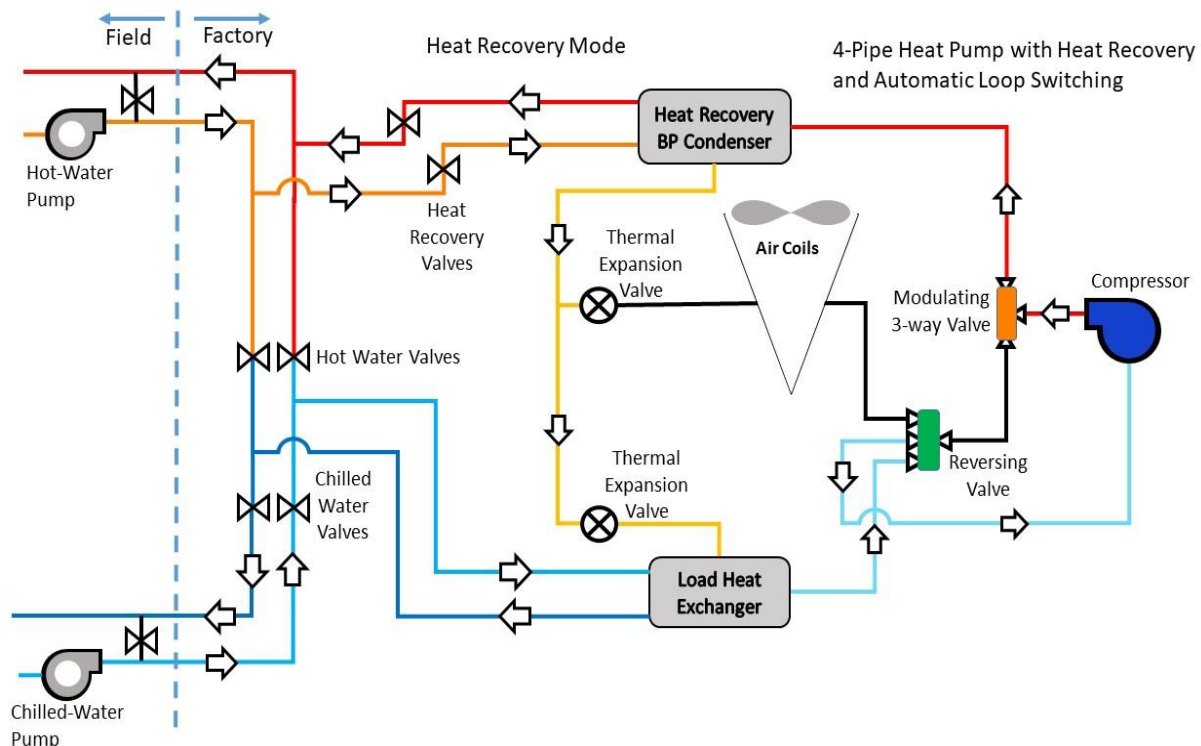

- Heat mode** - When there is not a cooling load, four-pipe AWHP units can produce heat, but require additional water piping and valves to separate the heating loop from the cooling loop. Four-pipe AWHP heating mode can be seen in Figure 7. As shown in Figure 7, the refrigerant-to-air heat exchanger is the energy source in the circuit, absorbing heat from the outdoor air, while the refrigerant-to-water is the energy sink in the circuit, rejecting heat to the heating water circuit.

During heating mode, the valves leading to the chilled water loop, from the load heat exchanger are closed. The machine is producing no chilled water, therefore heat recovery is not available so its isolation valves are closed as well. The valves leading from the load heat exchanger to the hot water loop are open.

Figure 7. Four-Pipe Heat Mode Operation

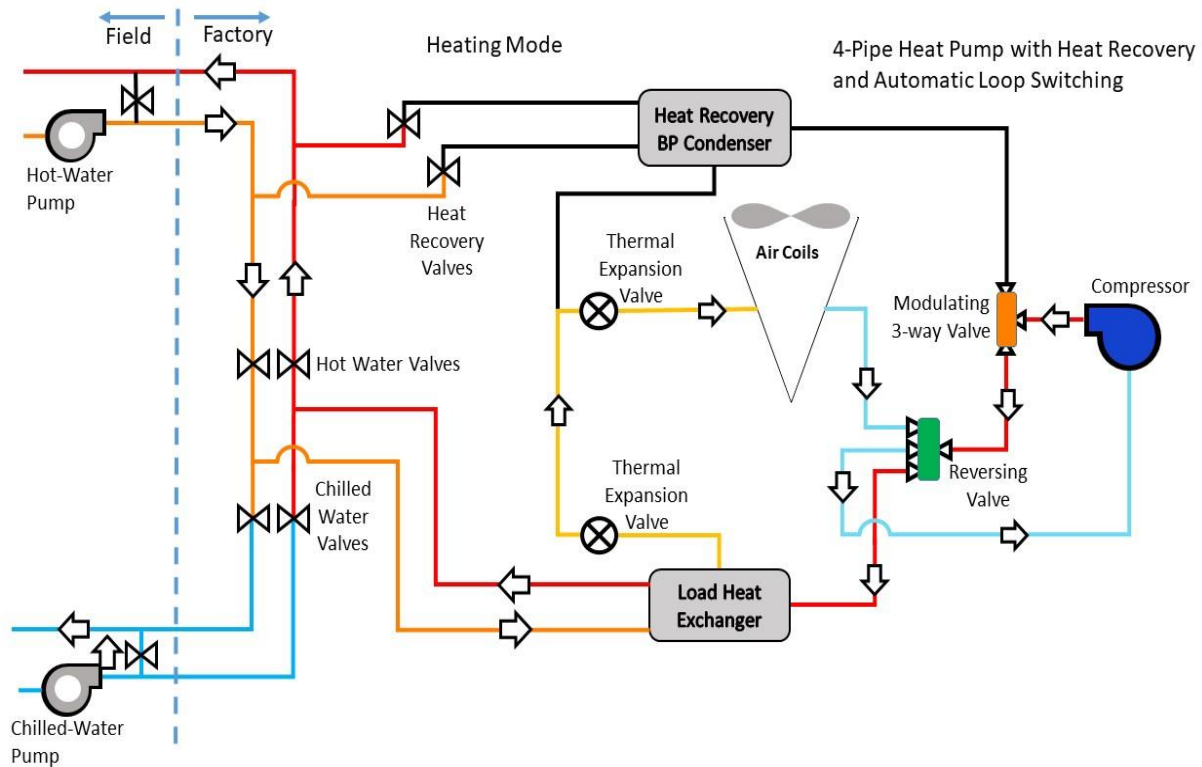

- Cooling Mode** – As shown in Figure 8, the refrigerant-to-water heat exchanger is the energy source for the refrigeration circuit, absorbing heat from the chilled water. The refrigerant-to-air coil is the energy sink, rejecting heat to ambient air. In this mode, the machine has the same operation as an air-cooled chiller. The building management system is not calling for simultaneous heating so the machine is in “cooling only” mode.

During cooling mode, the cooling water valves are open, while the heat recovery water valves and hot water valves are closed.

Figure 8. Four-Pipe Cooling Mode Operation

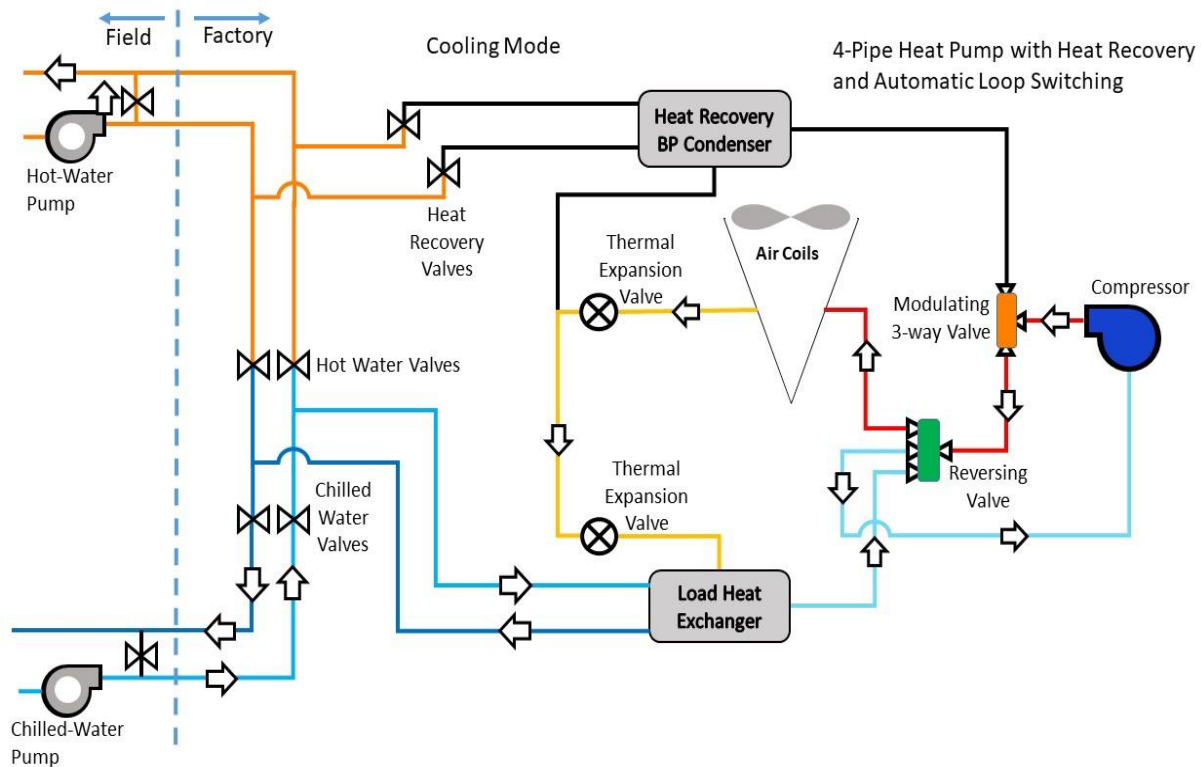

4. **Defrost Cycle** – Figure 9 shows the refrigeration circuit is in the cooling mode supplying heat to melt accumulated ice from the refrigerant-to-air heat exchanger. The return heating water is the source for the heat energy needed to defrost the outdoor air coil. The heat energy for defrost is extracted from the heating water loop.

During defrost mode, the hot water valves are open, while the heat recovery water valves and chilled water valves are closed.

Figure 9. Four-Pipe Defrost Operation Mode

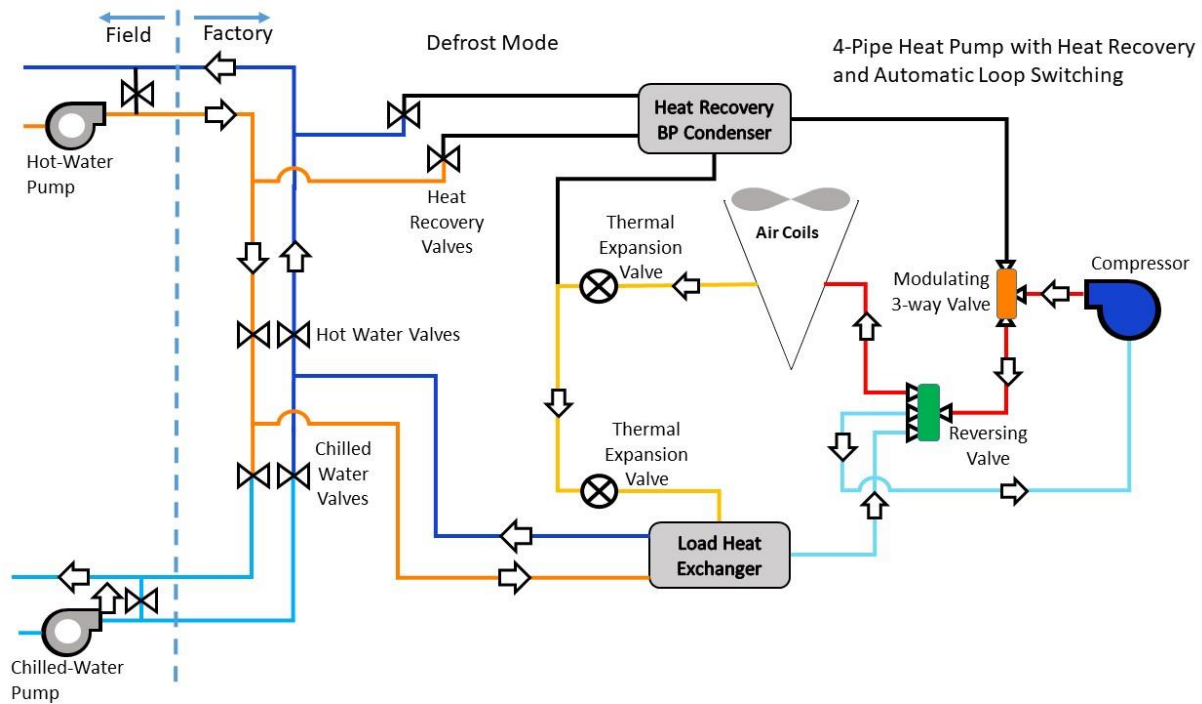

COOLING/HEATING CHANGEOVER CONTROL

Each AWHP unit mode of operation has a specific permissible range of operation. This includes limits on minimum and maximum outdoor air temperatures, entering and leaving heat exchanger fluid temperatures and fluid flow rates. When the system operating conditions are beyond the operating limits of the unit it will protect itself by not allowing compressor operation. When designing a system, it is important to understand the specified unit's operating limits to ensure the unit can cool and heat as required.

In addition, there may be limits to how frequently the building management system can request the unit switch between modes and how long it must operate in each mode before it can be switched back to the previous mode. When switching modes, time will need to be allowed so that the system temperatures can moderate enough for the unit to start in the new mode of operation. If the building management system rapidly switches the unit from heating to cooling or visa-versa the extreme temperature from the previous mode may cause unit operational issues in the newly commanded mode. For example, if the unit is operating in cooling mode producing 42°F chilled water and its operation is changed to heating mode with a requested setpoint of 120°F, this would initially result in a low condensing pressure which may cause the unit to trip a safety diagnostic. In this example, allowing a time duration for the loop to warm up before starting the heat pump could be a way to mitigate this trip potential.

The defrost cycle is automatically initiated by the unit control when frost accumulates on the air-source coil and impacts unit performance. The building management system can monitor the unit mode of operation or leaving fluid temperature to detect defrost mode operation. If required, the building management system can initiate operation of an auxiliary heater to mitigate the impact of defrost operation on the system heating supply fluid temperature.

AIR-TO-WATER HEAT PUMP SYSTEM SIZING

Because of the dramatic change in AWHP heating capacity, at low outdoor air temperatures, a careful analysis of unit capacity, sizing and selection is required. The outdoor air temperature significantly impacts the equipment full load heating capacity. A commonly used AHRI rating point for heating capacity is at 47°F ambient. However, the typical outdoor air design heating temperature is much colder resulting in a substantial capacity adjustment. Figure 10 shows the relationship between available heat pump capacity as a function of outdoor air temperature. Cold climates will see a reduction in both the rated capacity and maximum leaving water temperature that can be generated. It is important to understand where the maximum heating load and lowest heat pump capacity lines cross because at this point additional heat capacity is required. This additional capacity may come in the form of additional heat pump modules or auxiliary heat sources.

Figure 10. Ambient impact on heat pump leaving water temperature

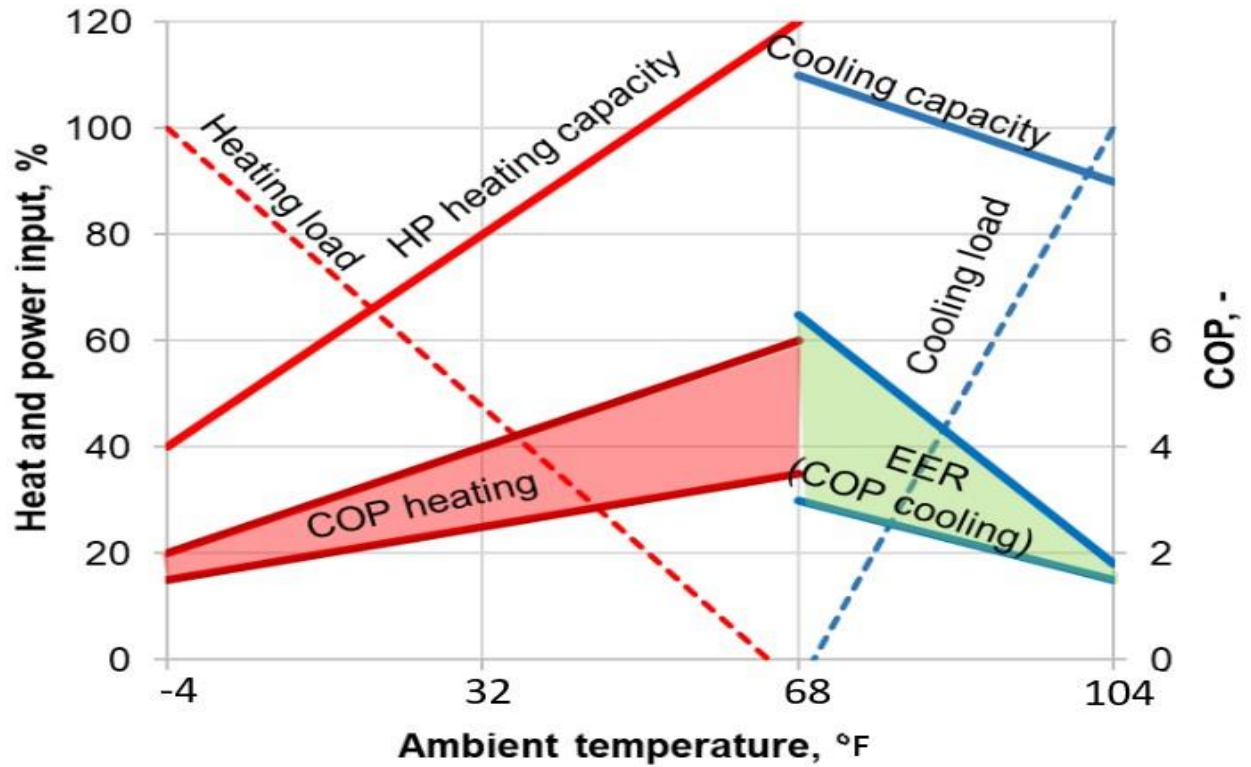

SPECIALIZED COMPRESSORS FOR HEAT PUMPS

Liquid injection compressors extend the ability for heat pumps to produce hot water at reduced ambient temperatures. The unique liquid injection solution extends the compressor envelope to extreme operating conditions and reduces the applied costs on the system.

Figure 11. Liquid Injection Compressor

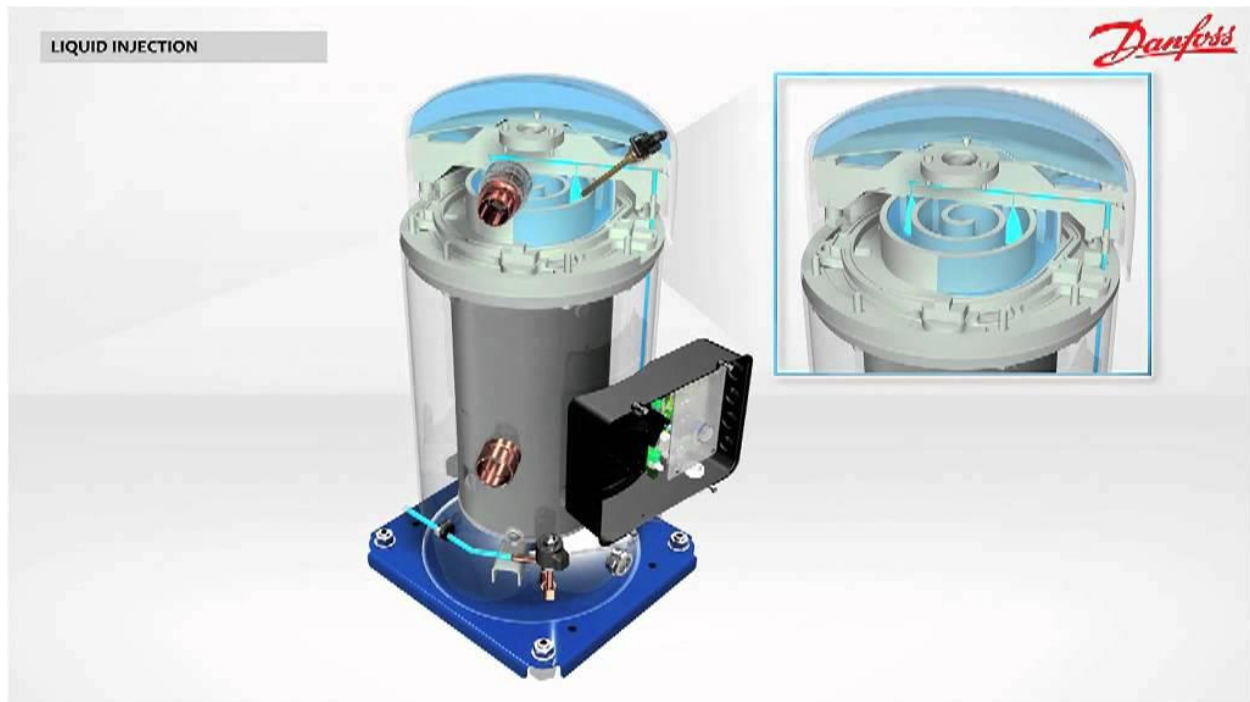

Heat pumps utilizing liquid injection compressors will be able to operate at very high condensing temperatures and at the same time with low evaporating temperatures. For example, an air-to-water heat pump, with liquid injection compressors, can produce up to 130°F water at 0°F ambient, up to 140°F at 10°F ambient and up to 146°F at 32°F ambient. Figure 12 shows the relationship between available heat pump leaving water temperature as a function of outdoor air temperature when using a liquid injection compressor. The green dot, in Figure 12, represents 125°F leaving water at 0°F ambient.

Figure 12. Leaving Water Temperature Limits Based on Ambient Temperature

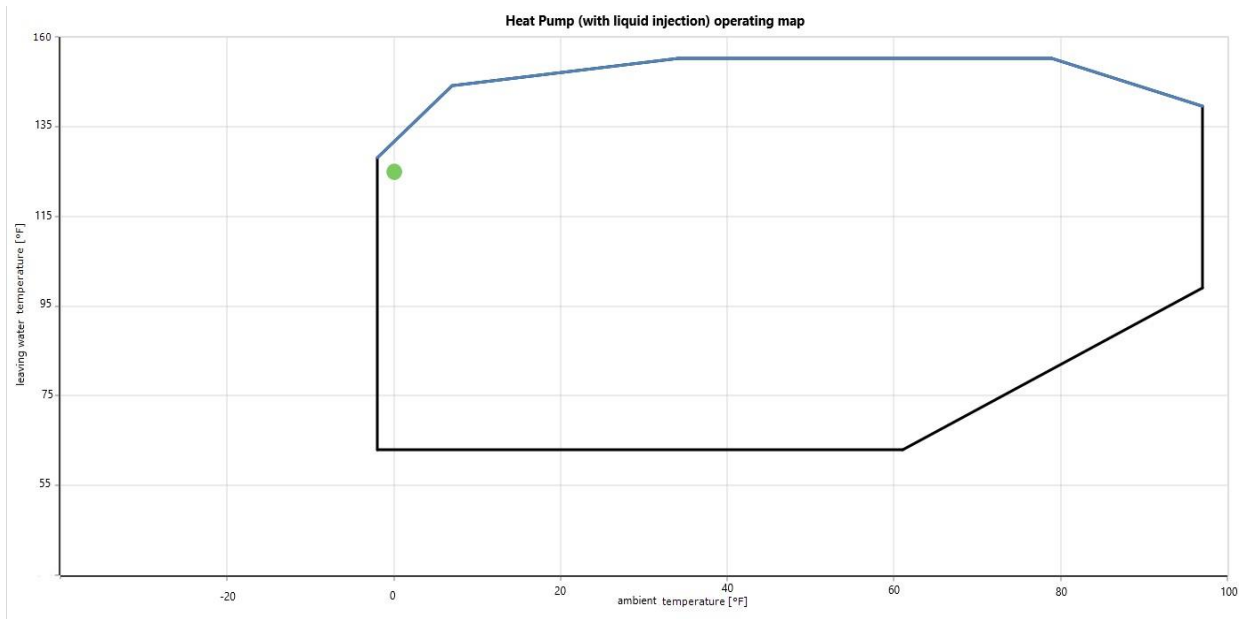

DEFROST IMPLICATIONS TO SIZING

Low outdoor air temperatures cause the outdoor coil temperature to drop below freezing, potentially resulting in frost accumulation. Defrost typically occurs below 47°F ambient. Air-to-water heat pump units will automatically enter defrost operation, when it is required.

Defrost operation results in a weighted performance derate to the equipment heating capacity. Some designer intuition is involved because the frequency, and therefore impact of defrost operation, is dependent on actual operating conditions. A derate factor should be applied to the required unit design capacity for the specified equipment capacity in the equipment schedules and schedule notes should clarify this has been done. This will help ensure equipment selections include the proper defrost impact. Defrost derates range from no derate, for “heating-only” machines operating in moderate climates to as low as 80% of the unit’s heating capacity at low ambient (0°F) operation. The defrost derate can be expressed in the form of an equation

where, Total Needed Unit Heating Capacity = $\frac{\text{Building Heat Requirement}}{\text{Defrost Derate Factor}}$

WEATHER EXTREMES AND AUXILIARY HEAT

Auxiliary Heat is defined as heat from an alternate source from the AWHPs that operates only when the AWHPs cannot operate because of outdoor ambient conditions or AWHP system component failure. If outdoor conditions are cold enough (such as below 0°F) AWHP units may not be able to operate. In northern climates this will occur with normal variations in weather. In other climate zones, it may be abnormal, but can be part of 20- or 50-year extreme conditions. Regardless of climate fluctuations, a plan for an alternate heat source is required given the operating limitations of heat pump equipment. If full auxiliary heat is to be provided in the design, then sizing for climate fluctuations (and extremes) would be a good design strategy. Since it is used infrequently, its impact on annualized carbon emissions is limited, so the use of high efficiency fossil fuel boilers should not be ruled out.

SIMULTANEOUS HEATING AND COOLING

When possible, it is advisable to have two or more heat pumps in a system design. Dividing the system capacity between two or more units provides multiple benefits. First, it improves system turn-down capability which is especially beneficial to the many operating hours at lower loads. Second, it provides adequate capacity to meet simultaneous heating and cooling loads and efficiently addresses design loads without the complexity of heat recovery. In buildings, simultaneous heating and cooling loads often exist between 55°F and 60°F outside air temperatures and can easily be met with one unit in cooling and the other in heating mode.

AWHP units perform at high efficiency in this mild temperature range which means that a heat recovery unit will have a relatively small efficiency benefit for the added cost. However, a heat recovery unit can eliminate the need to operate two AWHP units, both at low loads to meet the simultaneous loads. This can extend the life of the AWHP units as well as provide some system control and efficiency benefit.

Using two separate heat pumps requires a four-pipe distribution system. These are standard distribution loops and may be optimized for the supply temperatures, flows, and temperature changes as required by the air-side design. The air-side coil capacity may be controlled with two-way valves causing widely variable distribution pumping flow for both the chilled water and heating water distribution. This provides for significant operational flexibility and opportunities for pumping energy savings. At the heart of the system are decoupler lines. These lines provide the hydronic isolation that allows for optimization of flows and temperatures in both the distribution and production loops.

Decoupling greatly simplifies system design and allows an array of sizes and types of heat pump units that can be applied to best match building load requirements. The principal requirement for the heat pump selection is that it can produce the supply water temperature required for cooling or heating. The system designer should apply good piping principles when designing the primary/secondary chilled water system for heat pump systems.

HEATING LOOP VOLUME

The heating loop minimum fluid volume requirement is typically higher than chilled water loops. The key reason heating loops require greater volume is to compensate for unit defrost operation. When a unit goes into defrost the unit leaving fluid temperature drops rapidly. This is particularly so if only one refrigeration circuit is operating and goes into defrost. In a system with inadequate fluid volume at least three issues can occur:

1. The cold fluid can cause the air-handlers or terminal units to allow cold air into the space causing occupant discomfort.
2. The cold fluid can cause low temperature alarms or freeze trips in air handling units.
3. The return fluid temperature to the heat pump can get cold enough to cause a heat pump unit alarm.

Mitigating these problems for units with two refrigeration circuits that do not defrost at the same time requires a heating loop minimum fluid volume of 0.77 gals/per mBh heating rating point.ⁱ This is approximately nine gallons per rated heating ton at those conditions, for the largest

capacity heat pump in the system. The system volume is calculated based on the piping, coil, and heat pump internal volumes. For systems which do not meet the recommended fluid volume, a volume buffer tank must be installed in the heat pump heating **supply** line. Note that this is different than chilled water loops where a buffer tank, if needed, is typically installed in the return line to the chillers. Locating the buffer tank in the heating supply line allows it to moderate both the heating system supply water temperature and AHP return water temperature swings that occur during unit defrost cycles.

SUMMARY

An electrified cooling/heating system based on air-to-water heat pump technology provides high operating efficiency. However, careful consideration must be given to a number of unique system and equipment characteristics and operating limitations that are different from those in chilled water systems. These must be addressed in order to have an effective and reliable decarbonization system.

There are several key points that the design engineer should be mindful of when designing the system:

- Equipment selection should account for coldest design conditions as the outdoor air temperature has a significant effect on heat pump unit capacity and maximum available supply hot water temperature.
- Auxiliary heat may be required due to extremes in outdoor air temperature that can often exceed the operating range of the heat pump technology.
- Lower design and operating hot water supply temperatures results in more efficient heat pump unit operation.
- Proper system/equipment sizing is key to efficient and reliable operation. Improper equipment sizing penalizes system efficiency and shortens equipment operating life, therefore reducing the benefits of decarbonization of the system.

When taking these key points into account during the design process, the design engineer will have greater success in providing a highly flexible, efficient, and reliable electrified heating system. The products and systems available for commercial building electrified hydronic heating systems are maturing quickly. Contact your Jetson Sales Representative to discuss this and other high efficiency HVAC related topics.

REFERENCES

¹ Matteo Dongellini, Agostino Piazzi, *and* Gian Luca Morini, "On the influence of hydronic distribution loop on energy performance and indoor thermal comfort for air-to-water heat pump systems in residential buildings", AIP Conference Proceedings 2191, 020068 (2019) <https://doi.org/10.1063/1.5138801>

Jetson

Excellence in HVAC

**905 W. Cotton Street
Longview, TX 75604
Phone: 903-758-2900
www.JetsonHVAC.com**

**Air-to-Water Heat Pumps
Revision 230609**

It is the intent of Jetson to provide accurate up-to-date specification data. However, in the interest of ongoing product improvement, Jetson Innovations reserves the right to change specifications and/or design of any product without notice, obligation, or liability.