

WCCU Series Condensing Units

Installation, Operation & Maintenance Manual

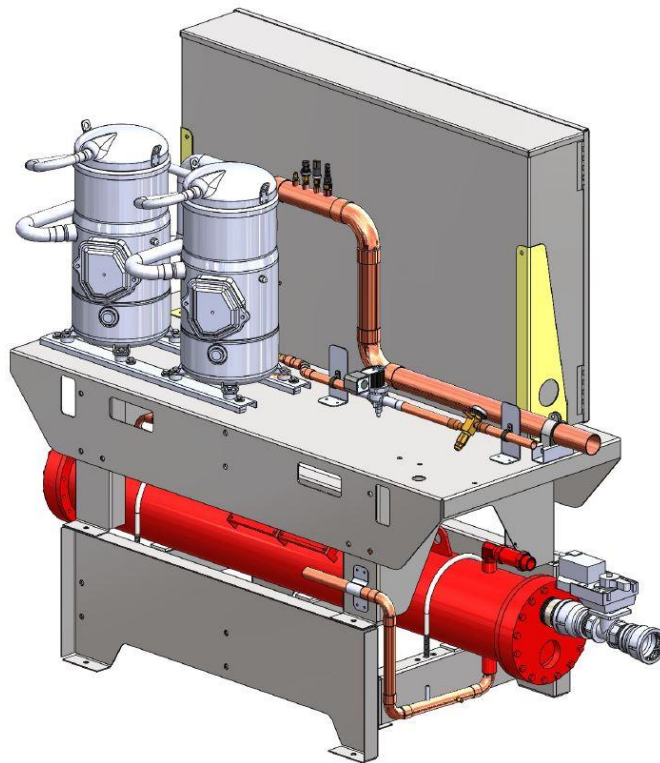

NTC

Napps Technology Corporation

Table of Contents

Model Number Description4
Installation5
Warnings and Cautions6
Unit Piping8
Refrigerant Piping.....8
Equipment Placement10
Electrical13
Maintenance16
General Data.....18
Electrical Data19
Single Circuit WCCU Wiring Diagram20
Dual Circuit WCCU Wiring Diagram.....21
Field Wiring Diagram22
Water Flow vs. Pressure Drop23
Literature Change History25

Model Number Description

Digit 1, 2, 3, 4 — Unit Type

WCCU = Water-Cooled Condensing Unit

Digit 5, 6, 7 — Unit Nominal Tonnage

020 = 20 nominal tons

030 = 30 nominal tons

040 = 40 nominal tons

050 = 50 nominal tons

065 = 65 nominal tons

075 = 75 nominal tons

Digit 8 — Unit Voltage

A = 208V/60/3

B = 230V/60/3

F = 460V/60/3

G = 575V/60/3

Digit 9, 10 — Design Sequence

A0 = Factory assigned

Digit 11 — Agency Listing

N = None

E = ETL/ETL-C Listed to meet U.S. and Canadian safety standards

Digit 12 — Condenser Water Regulating Valve

0 = None

1 = With

Digit 13 — Blank

0 = None

Digit 14 — Blank

0 = None

Digit 15 — Power Connection

T = Terminal block

D = Non-fused disconnect switch

F = Fused disconnect switch

Digit 16 — Short Circuit Rating (SCCR)

0 = Standard 5 kA rating

1 = Optional 100 kA rating

Digit 17 — Sound Attenuator

0 = No sound attenuation

3 = Compressor sound blanket(s)

9 = Factory sound enclosure cabinet

Digit 18 — Local Unit Controller Interface

0 = Keypad with dot pixel display

1 = 15.4" Color touchscreen

Digit 19 — Remote BMS Interface (Digital Comm)

0 = None

2 = LonTalk®

4 = BACnet® MS/TP

5 = BACnet IP

6 = MODBUS®

8 = Johnson N2

Digit 20 — Power Monitor

0 = None

1 = With

Digit 21 — Neoprene Isolator Pads

0 = None

1 = With

Digit 22 — Blank

0 = None

Digit 23 — Blank

0 = None

Digit 24 — Condenser Fluid Type

0 = Water

2 = Ethylene glycol

3 = Propylene glycol

Digit 25 — Special Options

0 = None

1 = With

Digit 26 — Condenser Heat Recovery

0 = No heat recovery

1 = Full heat recovery

Installation

Unit Inspection

When the unit is delivered, verify that it is the correct unit and that it is properly equipped. Compare the information, on the unit nameplate, with the ordering and submittal information

Inspection Checklist

To protect against loss due to damage incurred in transit, complete the following checklist upon receipt of the unit.

- Inspect the individual pieces of the shipment before accepting the unit. Check for obvious damage to the unit or packing material.
- Inspect the unit for concealed damage as soon as possible after delivery and before it is stored. Concealed damage must be reported within 15 days.
- If concealed damage is discovered, stop unpacking the shipment. Do not remove damaged material from the receiving location. Take photos of the damage, if possible. The owner must provide reasonable evidence that the damage did not occur after delivery.
- Notify the carrier's terminal of the damage immediately, by phone and by mail. Request an immediate, joint inspection of the damage with the carrier and the consignee.
- Notify the sales representative and arrange for repair. Do not repair the unit, however, until damage is inspected by the carrier's representative.

Loose Parts Inventory

Check all items against the shipping list. Items, which are shipped loose, could be placed inside the unit control panel for shipment. If the optional neoprene isolators are ordered, they are secured in place on the shipping skid or inside the unit control panel.

Unit Description

WCCU condensing units are designed for installation on a prepared surface, in a suitable weatherproof enclosure. The WCCU condensing units consist of two or three scroll compressors and an integral control panel mounted on a common base. The WCCU condensing unit is equipped with a shell-and-tube type, water cooled condenser.

All units are shipped with a holding charge of dry nitrogen. Units are dehydrated, leak tested, and controls are run through a dry functional test before shipment. The liquid line valve is closed for shipment to isolate the holding charge in the unit.

When installing the WCCU, be sure to install a liquid line solenoid valve, a filter drier, a sight glass, a thermostatic expansion valve and any other valves necessary to perform normal service functions.

The unit wiring diagram and installation and maintenance manual have been shipped with the unit and can be found in the unit control panel. Be sure to read installation and maintenance manual before installing and operating the unit.

Warnings and Cautions

WARNINGS and **CAUTIONS** appear in **boldface** type at appropriate points in this manual. Your personal safety and reliable operation of this equipment depend upon strict observance of these precautions. NTC assumes no liability for installation or service procedures performed by unqualified personnel.

Unit Nameplate

The unit nameplate is mounted on the inside of the control panel door. The nameplate provides the following information:

- Unit model number
- Unit serial number
- Refrigerant
- Maximum operating pressures
- Unit electrical requirements

Compressor Nameplate

The nameplate for the hermetic scroll compressor is mounted on the compressor housing, near the motor terminal junction box.

Storage

WCCU units are designed for indoor installation only. Store the unit in a suitable weatherproof enclosure.

CAUTION: Store these units in a protected area only. Do not store outdoors with a protective covering such as a plastic shroud. This can result in excessive water condensation that could damage controls and other components.

Noise Considerations

Locate the unit away from sound-sensitive areas. If necessary, install the optional isolators under the unit. Install vibration isolators in all piping and use flexible electrical conduit. Consult an acoustical engineer for critical applications

Foundation

A base or foundation is recommended for most installations. Provide a level surface strong enough to support the unit. A flexible (isolated) concrete foundation or footings at each loading point will reduce transmission of vibration. Install anchor bolts in the concrete to secure the unit. If the floor is warped, uneven or in poor condition, make necessary repairs before positioning the unit. Once the unit is in place, it should be level, within ¼” over its entire length and width.

Clearances

Provide enough space around the unit to allow the installation and maintenance personnel unrestricted access to all service points. There should be adequate clearance for condenser and compressor servicing. A minimum of three feet is recommended for compressor service. A minimum clearance of 3’6” is required to open the control panel doors. In all cases, local codes will take precedence over these recommendations.

Ventilation

Provisions must be made to remove heat generated by unit operation from the equipment room. Ventilation must be adequate to maintain an ambient temperature lower than 125°F.

The condenser relief valve on WCCU units must be vented in accordance with all local and national codes.

Drainage

Locate the unit near a large capacity drain for condenser drain-down during shutdown or repair.

Handling

WCCU units are shipped stretch wrapped and bolted to a shipping skid.

WARNING! Do not remove the unit from the shipping skid until it is at the installation location. Moving these units when not properly secured to the skid can result in personal injury, or death, and can seriously damage the unit.

The skidded unit can be moved by using a fork truck of suitable capacity.

WARNING! Any on-site lifting equipment must be capable of handling the weight of the unit with an adequate safety factor. Use of under-capacity lifting equipment can result in personal injury, or death, and can seriously damage the unit.

When moving the unit, the lifting forks must be positioned at either end of the unit, under the shipping skid. Lift the unit and move it to the desired location.

Once the unit is at the installation location, remove the stretch wrap. Inspect the unit for damage and report if damage is found.

The optional unit isolators (if ordered) are secured to the shipping skid or in the unit control panel. Other optional items such as the water regulating valve may be attached to the skid or shipped separately.

WARNING! To prevent injury or death, and damage to the unit, the capacity of the lifting equipment must exceed the unit lifting weight by an adequate safety factor.

Rigging/Lifting Procedure

If the WCCU is not moved using a forklift, and the forklift pockets provided as part of the unit's frame, then the WCCU should be lifted and moved by using lifting rails as outlined in Step 1 through Step 8.

1. Remove the stretch wrap from the unit, leaving the unit mounted to the skid.
2. Insert lifting rails through the frame. Secure the lifting rails to the unit frame by torquing 1/2" bolts to 70 ft-lbs.
3. Install clevis connectors or equivalent at each end of the lifting rails.
4. Attach certified lifting chains (cables) to these points. Each chain (cable) alone must be strong enough to lift the unit.
5. Attach chains (or cables) to a lifting beam. Position the chains (cables) so that they do not contact the unit piping or the unit control panel. Use a suitable spreader bar to ensure proper weight distribution.
6. Remove the bolts that secure the unit to the shipping skid.
7. Raise the unit just off the skid to make sure that the unit is level when lifted. Adjust chain (cable) lengths as required for level lifting.
8. Lift the unit off of the skid and place in the installation location.

Direct Mounting

The unit can be installed directly on a rigid mounting surface as long as the surface is level and will support the weight of the unit. A hole is provided in the unit mounting brackets at each of the four unit mounting locations. Provide a means of securely anchoring the unit to the mounting surface. Level the unit carefully.

Unit Piping

General Water Piping Recommendations

Make water piping connections to the condenser. Isolate and support piping to prevent stress on the unit. Use flanged ells or spool-pieces to facilitate service procedures. Construct piping according to local and national codes. Insulate and flush the piping before connecting the unit.

Caution: To prevent equipment damage, bypass the unit if using an acidic flushing agent.

Use a pipe sealant of Teflon tape on all water connections. Minimize heat gain and prevent condensation by insulating all chilled water piping.

Caution: To prevent damage to water piping, do not over-tighten connections.

Condenser Water Piping

Condenser piping components and layout vary, depending on the water source and connection locations. The optional water regulating valve maintains condensing pressure and temperature by throttling water flow leaving the condenser in response to compressor discharge pressure. Adjust the regulating valve for proper operation during unit start-up. Under full load conditions the water temperature rise should be 10° F, producing a flow rate in the range of 3 gpm per ton. Condenser piping must be in accordance with all local and national codes.

Water Treatment

Using untreated or improperly treated water in these units may result in inefficient operation and possible tube damage. Consult a qualified water treatment specialist to determine if treatment is needed.

Caution: The use of untreated or improperly treated water in these units may result in scaling, erosion, corrosion, algae or slime. The services of a qualified water treatment specialist should be engaged to determine if treatment is needed. NTC warranty specifically excludes liability for corrosion, erosion or deterioration of NTC equipment. NTC assumes no responsibilities for the results of the use of untreated or improperly treated water or saline/brackish water

Water Pressure Relief Valves

Install a water pressure relief valve in the condenser leaving water line. Water vessels with close-coupled shutoff valves have a high potential for hydrostatic pressure buildup on a water temperature increase. Refer to applicable codes for relief valve installation guidelines.

Refrigerant Piping

General

The refrigerant pipe sizes selected must be within the velocity and pressure drop limitations required for proper system operation. It is essential that refrigerant piping be properly sized and applied, since these factors have a significant effect on system performance and reliability.

Note: Piping should be sized and laid out according to the job plans and specifications. This should be accomplished when the system components are selected.

Caution:

Discharge lines, liquid lines, and hot gas bypass lines that are 1-3/8 inches OD and smaller, with type-L copper, are suitable for use with R-410A. These same lines sized at 1-5/8 inches OD and larger must use type-K or thicker walls. The use of lower grade tubing may cause operating problems or injury.

Liquid Line Components

Thermostatic expansion valves, refrigerant sight glasses, solenoid valves, Schrader valves and filter dryers must be installed for proper operation.

Install shutoff valves in the liquid line to isolate the filter drier for service.

Liquid Line Sizing

The liquid line diameter should be as small as possible, while maintaining acceptable pressure drop. This will minimize the required refrigerant charge and increase compressor life.

Liquid risers in a system require an additional 0.5 psig pressure drop per each foot of vertical rise. If riser length exceeds 15 feet, a larger diameter and/or shorter liquid line may be required to provide required subcooling at the expansion valve. The line does not have to be pitched. Basic liquid line sizing parameters for these units are:

- Maximum Liquid velocity...600 fpm.
- Maximum allowable liquid line pressure drop7 psig (1°F).

Liquid lines are not usually insulated. If, however, the line runs through an area of high ambient temperature (e.g. boiler room), subcooling may drop below required levels.

Liquid lines passing through these warm spaces should be insulated.

Suction Line Sizing

Gas velocity is another consideration when sizing suction lines. It has been found that the minimum velocity requirement to move oil in horizontal suction lines is 500 fpm. For vertical up-flow suction lines, it must be increased to 1000 fpm. Keeping all suction line velocities below 4000 fpm will avoid excessive and undesirable noise levels.

- Maximum allowable suction line pressure drop3 psig.

Initial Leak Test

As shipped, WCCU Condensing Units contain a holding charge of nitrogen only. Before connecting refrigerant piping, momentarily crack open a Schrader valve on the liquid line to ensure that the unit is pressurized. If no gas escapes thru the valve, leak test the unit to determine the source of the refrigerant leak prior to installation and repair any leaks located.

WARNING! Always install a pressure regulator, shutoff valves, and gauges to control pressures during leak testing procedures. Unregulated pressures may cause line ruptures, equipment damage, or an explosion, which could result in personal injury or death.

Equipment Placement

Minimize Distance Between Components

For a split air-conditioning system to perform as reliably and inexpensively as possible, the refrigerant charge must be kept to a minimum. To help accomplish this design goal:

- Site the outdoor unit as close to the indoor unit as possible.
- Route each interconnecting refrigerant line by the shortest and most direct path so that line lengths and riser heights are no longer than absolutely necessary.
- Use only horizontal and vertical piping configurations.

- Determine whether the total length of each refrigerant line requires NTC review. Be sure to account for the difference in elevations of the indoor and outdoor units when calculating the total line length.

Interconnecting lines of 150 lineal ft (45.7 m) or less do not require NTC review, but only a limited amount may be in a riser (see Figure 1. Allowable elevation difference: Compressor above evaporator and Figure 2. Allowable Elevation Difference: Evaporator above condenser).

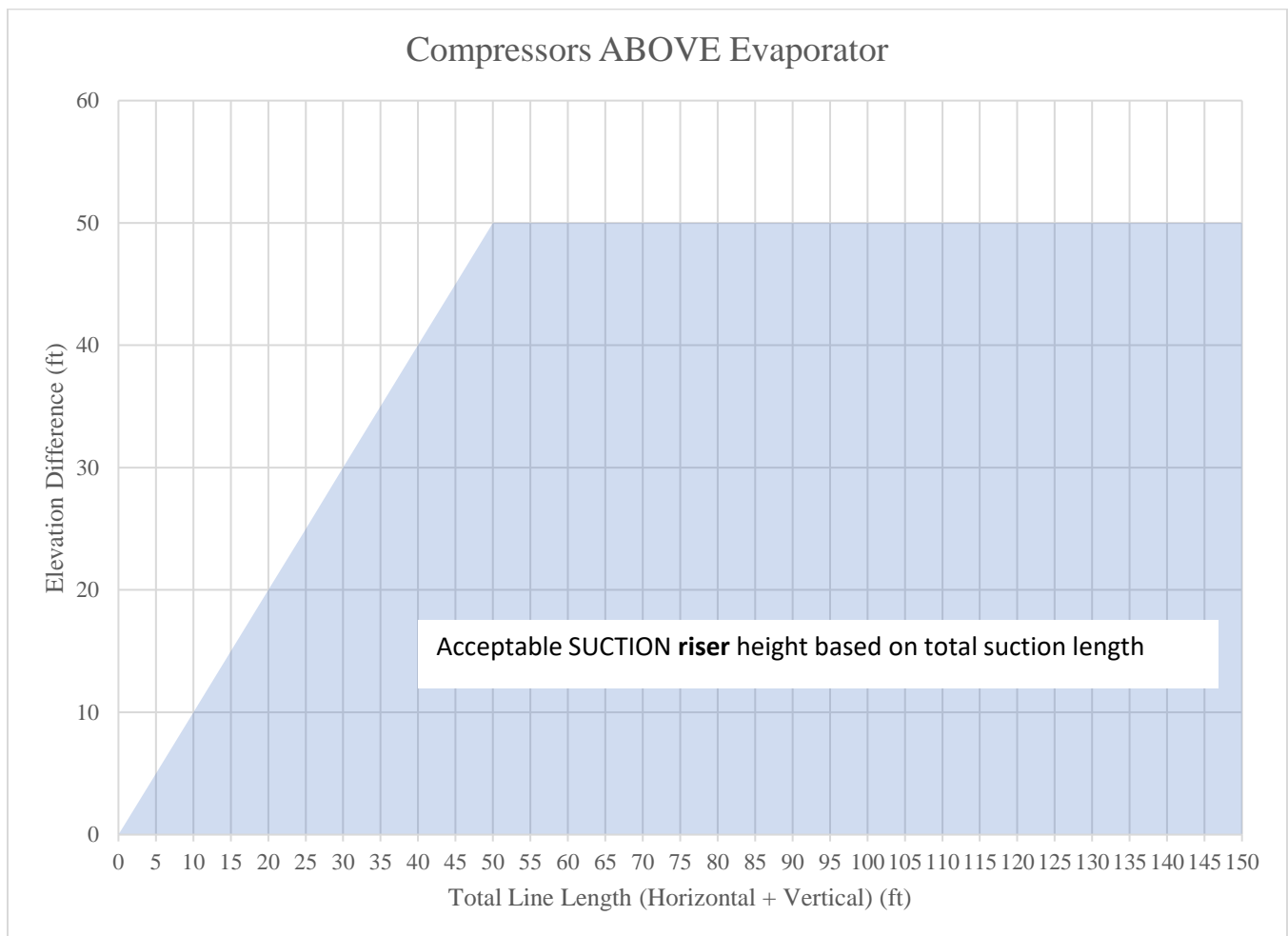

Figure 1. Allowable elevation difference: Compressor above evaporator

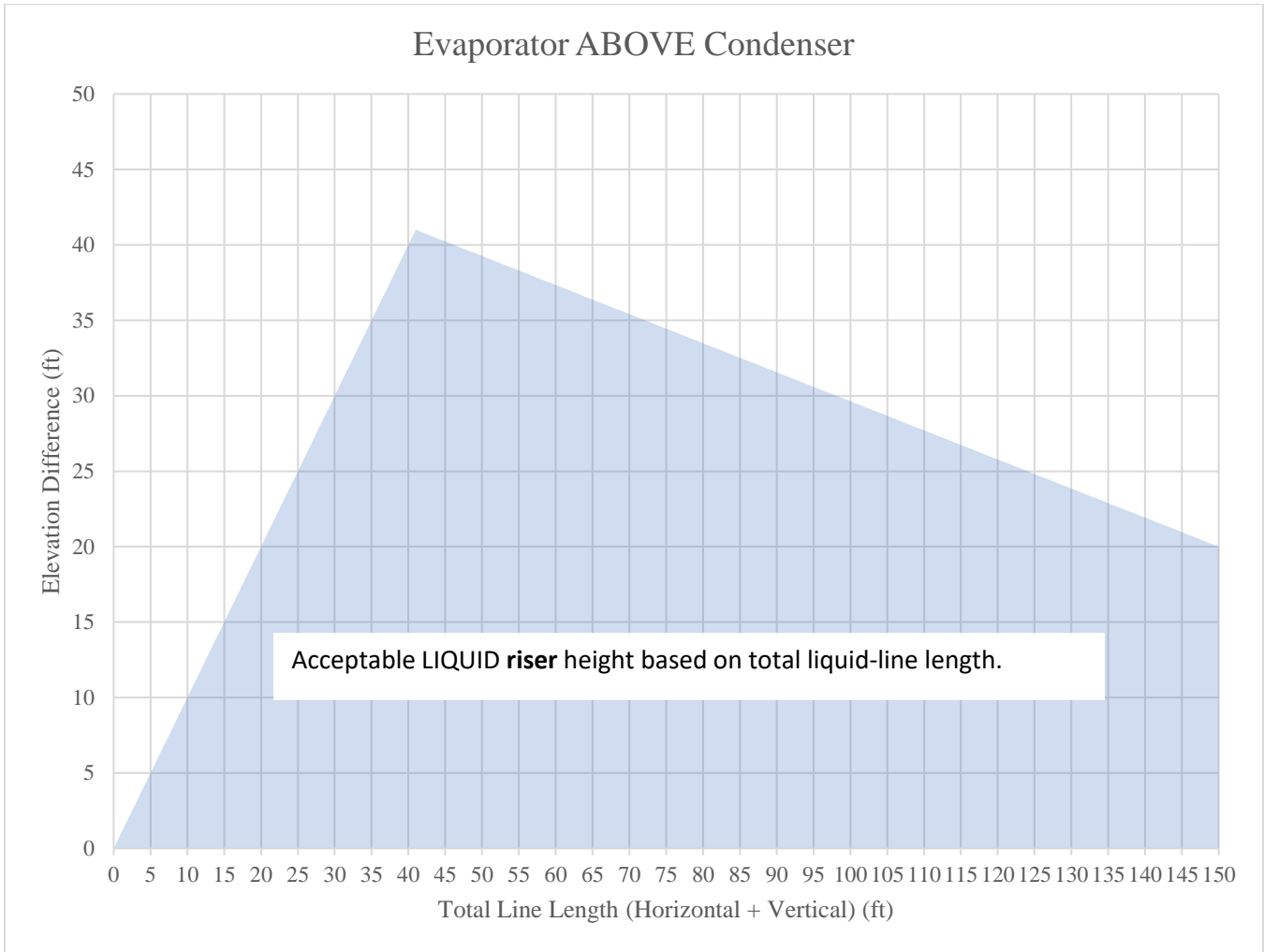

Figure 2. Allowable Elevation Difference: Evaporator above condenser

Interconnecting refrigerant piping between condensing unit and evaporator

The interconnecting piping is supplied by others and good engineering practice should be used in sloping and trapping the lines. Recommended line sizes for use with specific NTC modules are:

		WCCU 20	WCCU 30	WCCU 40	WCCU 50	WCCU 65	WCCU 75
Refrigerant Circuits		1	1	2	2	2	2
Minimum Step (tons)		10	15	10	12.5	15	15

Suction Lines							
50 foot equivalent length	Horizontal (& drops)	1-5/8	2-1/8	1-5/8	1-5/8	2-1/8	2-1/8
	Vertical (up)	1-5/8	2-1/8	1-5/8	1-5/8	2-1/8	2-1/8
75 foot equivalent length	Horizontal (& drops)	1-5/8	2-1/8	1-5/8	2-1/8	2-1/8	2-1/8
	Vertical (up)	1-5/8	2-1/8	1-5/8	1-5/8	2-1/8	2-1/8
100 foot equivalent length	Horizontal (& drops)	1-5/8	2-1/8	1-5/8	2-1/8	2-1/8	2-1/8
	Vertical (up)	1-5/8	2-1/8	1-5/8	1-5/8	2-1/8	2-1/8

Liquid Lines							
50 foot equivalent length		3/4	7/8	3/4	3/4	7/8	1-1/8
75 foot equivalent length		3/4	7/8	3/4	3/4	7/8	1-1/8
100 foot equivalent length		3/4	7/8	3/4	3/4	7/8	1-1/8

Electrical

General Recommendations

The wiring procedures, as described in this portion of the manual, must be accomplished to obtain proper operation of the basic WCCU unit.

WARNING! To prevent injury or death, disconnect electrical power source before completing connections to the unit.

All wiring must comply with National Electrical Code (NEC) and state and local requirements. Outside the United States, the national and/or local electrical requirements of other countries shall apply. The installer must provide properly sized system interconnecting and power supply wiring with appropriate fused disconnect switches. Type and locations of disconnects must comply with all applicable codes.

Caution: To prevent corrosion and overheating at terminal connections, use copper conductors, sized per NEC and based on nameplate RLA.

Caution: All wiring must comply with applicable local and national codes.

Caution: Type and location of fused disconnect switches must comply with applicable local and national codes.

Minimum circuit ampacities, recommended fuse sizes and other unit electrical data are provided on the unit nameplate.

Unit Power Wiring

The installing contractor must connect appropriate power wiring to the terminal block or unit-mounted disconnect in the power section of the unit control panel. Electrical schematics and

component location drawings are also mounted on the inside of the control panel door.

The unit power fused disconnect switch should be located in the general area of the unit, to comply with NEC or local codes. Some codes require line-of-sight disconnect locations. The unit disconnect can be used as an emergency shutdown device.

Unit Control Wiring

The installing contractor must connect the unit to a **temperature control device** with an appropriate number of control stages.

A **liquid line solenoid valve(s)** must be installed. It is recommended that the evaporator be divided into the same number of circuits as the condenser, with a solenoid valve on each circuit.

Terminals are provided for the **installation of devices intended to prevent the unit from operating** under certain conditions. These devices may include flow switches, building controllers, pump auxiliary contacts, etc. Refer to the unit wiring diagram for proper terminal location. To install more than one device, put the contacts of all the devices in series.

Terminals are provided for the **installation of additional safety devices**. These devices may include freeze-stats, high-temperature switches, low temperature switches, etc. Refer to the unit wiring diagram for proper terminal location. Contacts installed here should be normally closed, and open during a fault condition. When a contact in this position opens, the unit will lock out and require a reset to continue operating. To install more than one additional safety device, put the contacts in series.

Scroll Compressor Electrical Phasing

It is important that proper rotation of the scroll compressor be established before the machine is

started. Proper motor rotation requires confirmation of the electrical phase sequence of the power supply. The motor is internally connected for clockwise rotation with the inlet power supply phased “ABC” or “L1, L2, L3”.

The order in which the three voltages of a three-phase system succeed one another is called phase sequence or phase rotation. When rotation is clockwise, phase sequence is usually called “ABC” and when counterclockwise, “CBA”.

This direction may be reversed by interchanging any two of the line wires. It is this possible interchange of wiring that makes a phase sequence indicator necessary, if the operator is to quickly determine the phase rotation of the motor.

Setting the Proper Electrical Phase Sequence

Proper compressor motor electrical phasing can be quickly determined and, if necessary, corrected before starting the unit. Use a quality Phase Sequence indicator and follow this procedure.

1. Verify that all operating controls for the unit are in the “Off” position.
2. Deenergize the electrical disconnect or circuit protection switch that provides line power to the power distribution block in the unit control panel
3. Connect the phase sequence indicator leads to the power distribution block as follows:

<u>Phase Seq. Lead</u>	<u>Terminal ID</u>
Black (Phase A)	L1
Red (Phase B)	L2
Yellow (Phase C)	L3

4. Turn power on by closing the unit supply power fused disconnect switch.

5. Read the phase sequence displayed on the indicator. The “ABC” LED on the face of the phase indicator will glow if phase sequence is ABC

WARNING! To prevent injury or death due to electrocution, take extreme care when performing service procedures with electrical power energized.

6. If the “CBA” indicator glows instead, deenergize the unit main power disconnect and switch two line leads on the power distribution block in the unit control panel. Close the main power disconnect and recheck phasing.
7. Deenergize the unit disconnect and remove the phase indicator.

Unit Voltage

Electrical power to the unit must meet stringent requirements for the unit to operate properly. Total voltage supply and voltage imbalance between phases should be within the tolerances discussed as follows.

Voltage Supply

Measure each leg of supply voltage at the line voltage disconnect switches. Readings must fall within the range of 187-253 volts for units with a nameplate voltage of 208/230 volt and 414-506 volts for units with a nameplate voltage of 460 volts. If voltage on any leg does not fall within tolerance, notify the power company and request correction of this situation before operating the unit. Inadequate voltage to the unit will shorten the life of relay contacts and compressor motors.

Voltage Imbalance

Excessive voltage imbalance between phases in a three-phase system will cause motors to overheat and eventually fail. Maximum allowable imbalance is 2 percent. Voltage imbalance is defined as 100 times the maximum deviation of the three voltages (three phases) subtracted from the average (without regard to sign), divided by the average voltage.

Equipment Grounds

Provide proper grounding at the connection point provided in the unit control panel.

Installation Checklist

As the unit is installed, complete this checklist to verify that all recommended procedures are accomplished before the unit is started. This checklist does not replace the detailed instructions given in previous sections of this manual. Read the entire installation section carefully to become familiar with the procedures before installing the unit.

Unit Location

- Inspect installation location for adequate ventilation.
- Provide drain facilities for condenser.
- Remove and discard all shipping material (skid, etc.).
- Inspect to ensure that all service access clearances are adequate.
- Install optional neoprene isolators (if required).
- Secure the unit to the mounting surface.
- Level the unit.

Condenser Connections

- Make condenser water connections.
- Install a water regulating valve in the water outlet line, if required.
- Install shutoff valves, temperature sensors, plugged clean-out tees, and pressure gauges in the water inlet and outlet lines.

- Install a water strainer and pressure reducing valve on the water inlet piping.
- Install drain piping with shutoff valves.
- Install a manual or automatic bypass valve in the cooling tower water supply (if used).
- Install refrigerant discharge piping for the condenser relief valve.
- Flush and clean all condensing water piping.

Refrigerant Piping

- Perform the initial leak test.
- Connect a properly sized and constructed liquid line (with charging valve, solenoid valve, filter drier, sight glass, and expansion valve) to the liquid line connection on the condenser.
- Connect a properly sized and constructed suction line from the evaporator to the suction line connection at the compressor.
- Insulate the suction line. Also insulate the hot gas bypass line (if used).
- Insulate the lengths of discharge or liquid line that are exposed to extremes in temperature.
- Leak test the unit and all piping connections.

Power Supply Wiring

- Connect proper power supply wiring to the power distribution block (or unit mounted disconnect) in the unit control panel.
- Connect proper power supply wiring, with fused disconnects, to the condenser water pump starter, to the cooling tower fan starter (if used).
- Connect proper power supply wiring to the evaporator fan coil.

System Interconnection Wiring

- Connect proper wiring to interlock the condenser water pump and the cooling tower operation with unit start-up.
- Provide proper wiring to interlock the unit start-up with airflow switch operation.
- Connect proper wiring to interlock the liquid line solenoid valve operation with unit call for cooling.

Maintenance

Compressor Oil

Oil Level. While the compressor is running, the oil level may be below the sight glass but still visible through the sight glass. The oil level should never be above the sight glass.

Oil Appearance. If the oil is dark and smells burnt, it was overheated because of compressor operation at extremely high condensing temperatures, a compressor mechanical failure, or occurrence of a motor burnout. If the oil is black and contains metal flakes, a mechanical failure has occurred. This symptom is often accompanied by a high amperage draw at the compressor motor.

Note: If a motor burnout is suspected, use an acid test kit to check the condition of the oil. If a burnout has occurred, test results will indicate an acid level exceeding 0.05 mg KOH/g.

Note: The use of commercially available oil additives is not recommended. Liability for any detrimental effects that the use of non-approved products may have on equipment performance or longevity must be assumed by the equipment owner, equipment servicer, or the oil additive manufacturer.

Compressor Motor Winding Thermostat

Each motor winding thermostat is a pilot-duty control, designed to stop compressor operation if

the motor windings become hot due to rapid cycling, loss of charge, abnormally low suction temperatures, or the compressor running backwards.

Compressor Electrical Phasing

Proper phasing of the electrical power is critical for proper operation and reliability of the scroll compressor. If the compressor electrical phasing is incorrect, the motor will draw low current, the suction and discharge pressures will change very little, and a rumble or rattle may be heard.

Scroll Compressor Functional Test

Since the scroll compressor does not use discharge or suction valves, it is not necessary to perform a pump-down capability test, i.e. a test where the liquid line valve is closed and the compressor is pumped in a vacuum to confirm it will pump-down and hold.

Caution: Do not pump the scroll compressor into a vacuum. Scroll compressors can pull internal low vacuums when the suction side is closed or restricted. This result in compressor damage or failure. It may also trip the circuit breakers, blow fuses, or trip the discharge thermostat.

The proper procedure for checking scroll compressor operation is outlined below:

1. Verify that the compressor is receiving supply power of the proper voltage.
2. With the compressor running, measure the suction and discharge pressures to determine whether or not they fall within the normal operating ranges for the unit.
3. If the operating pressures are not correct, see “Scroll Compressor Electrical Phasing”.

Compressor Operational Noises

Because the scroll compressor is designed to accommodate liquids (both oil and refrigerant), for short periods, without causing compressor damage, there are some characteristic sounds that may be heard. These sounds, which are described below, are normal and do not indicate that the compressor is defective.

At low condensing temperature start-up: When the compressor starts up under low condensing temperatures, the initial flow rate of the compressor is low, due to the low condensing pressure. This causes a low differential across the thermal expansion valve that limits its capacity. Under these conditions, it is not unusual to hear the compressor rattle until the suction pressure climbs and the flow rate increases. These sounds are normal and do not affect the operation or reliability of the compressor.

Excessive Vibration

If the compressor vibrates and does not pump, check the compressor phasing as described in “Scroll Compressor Electrical Phasing” and check the oil level and the oil’s appearance.

Periodic Maintenance

Perform all of the indicated maintenance procedures at the intervals scheduled. This will prolong the life of the unit and reduce the possibility of costly equipment failure.

Monthly

- Check compressor oil level.
- Check unit refrigerant charge by measuring sub-cooling or visually checking the sight glass for the presence of bubbles.

Low Suctions

Low suctions can be caused by a plugged screen on the compressor suction inlet. If the screen is plugged, the pressure in the oil sump, as measured at the oil charging valve, will be lower than the suction pressure measured at the evaporator.

Also, low suction pressures may be caused by low evaporator load. Other symptoms that may accompany low suctions include a rattling sound emitted from the compressor or an open motor winding thermostat or discharge thermostat.

Excess Amp Draw

Normally this condition occurs either because the compressor is operating at an abnormally high condensing temperature or because of low voltage at the compressor motor. Motor amp draw may also be excessive if the compressor has internal mechanical damage. In this situation, vibration and discolored oil can also be observed.

- Check refrigerant superheat at the compressor suction line. Superheat should be in the range of 10°-20°F.
- Check compressor phasing (See “Scroll Compressor Electrical Phasing”).

Annually

- * With the unit disconnect switch deenergized, inspect the panel wiring. All electrical connections should be secure. Inspect the compressor contactors. If the contacts appear severely burned or pitted, replace the contactor. Do not clean the contacts.
- * Remove any accumulation of dust and dirt from the unit.
- * Check condenser water flow rate.
- * With unit operating, check refrigerant discharge and suction pressures.

General Data

Unit Size (Nominal Tons)		20	30	40	50	65	75
Compressor							
Quantity	each	2	2	3	3	3	3
Nominal Tons @ 60 Hz ¹	tons	10/10	15/15	10/10, 20	12/12, 25	15/15, 30	15/15, 40
Steps of Unloading	%	100-50	100-50	100-75- 50-25	100-75- 50-25	100-75- 50-25	100-79- 57-21
Compressor Sound Power Data ²	dBa	81.0	84.0	87.2	87.5	90.2	91.8
Compressor Sound Data with Sound Blankets Only ²	dBa	75.0	78.0	82.8	83.0	85.8	87.5
Compressor Sound Data with Cabinet ²	dBa	67.0	70.0	75.2	75.5	78.2	79.8
Shell & Tube Condenser							
Water Storage	gal	3.0	4.5	5.5	7.4	9.2	9.2
Minimum Flow	gpm	28	39	49	65	84	84
Maximum Flow	gpm	119	167	207	271	342	342
Refrigerant							
Refrigerant		R-410A	R-410A	R-410A	R-410A	R-410A	R-410A
Number of Independent Refrigerant Circuits		1	1	2	2	2	2
Refrigerant Charge Per Circuit (approx.) ³	lb.	25	37	24, 24	26, 26	31, 31	33, 33
Oil Type		POE 160SZ	POE 160SZ	POE 160SZ	POE 160SZ	POE 160SZ	POE 160SZ
Oil Charge (each compressor)	oz	112/112	113/113	112/112, 227	112/112, 227	112/112, 227	112/112, 227

Notes:

1. Data containing information on two circuits formatted as follows: Circuit 1, Circuit 2
2. Compressor manufacturer sound power is given at rated compressor AHRI conditions measured in free space
3. Refrigerant charge will vary depending on other system components, including, but not limited to, refrigerant line length and diameter.

Electrical Data

Size	Rated Voltage	Compressor					Wiring		
		Qty	# of Refrig. Cir.	Nom. Tons	RLA (each)	LRA (each)	MCA	Max Fuse Size	Recommend Dual Element Fuse Size
20	208-230/60/3	2	1	10/10	39/39	267/267	88	125	100
	460/60/3 & 50Hz				19/19	142/142	42	60	50
	575/60/3				15/15	103/103	35	50	40
30	208-230/60/3	2	1	15/15	48/48	351/351	108	150	125
	460/60/3 & 50Hz				25/25	197/197	56	80	60
	575/60/3				22/22	135/135	50	70	60
40	208-230/60/3	3	2	10/10, 20	39/39, 67	267/267, 485	162	225	175
	460/60/3 & 50Hz				19/19, 33	142/142, 215	78	110	90
	575/60/3				15/15, 26	103/103, 175	64	80	70
50	208-230/60/3	3	2	12/12, 25	41/41, 82	304/304, 560	185	250	225
	460/60/3 & 50Hz				19/19, 40	147/147, 260	88	125	100
	575/60/3				17/17, 29	122/122, 210	69	90	80
65	208-230/60/3	3	2	15/15, 30	48/48, 109	351/351, 717	232	300	250
	460/60/3 & 50Hz				25/25, 51	197/197, 320	113	150	125
	575/60/3				22/22, 38	135/135, 235	93	125	110
75	208-230/60/3	3	2	15/20, 35	48/48, 122	351/351, 1010	248	350	300
	460/60/3 & 50Hz				25/25, 68	197/197, 344	134	200	150
	575/60/3				22/22, 46	135/135, 327	102	125	110

Notes:

1. Use copper conductors only.
2. Local codes may take precedence.
3. Data containing information on two circuits formatted as follows: Circuit 1, Circuit 2
4. Voltage Utilization Range: ± 10% of rated voltage. Rated voltage (use range): 208-230/60/3 (187-253), 460/60/3 (414-506), 575/60/3 (518-632).

Single Circuit WCCU Wiring Diagram

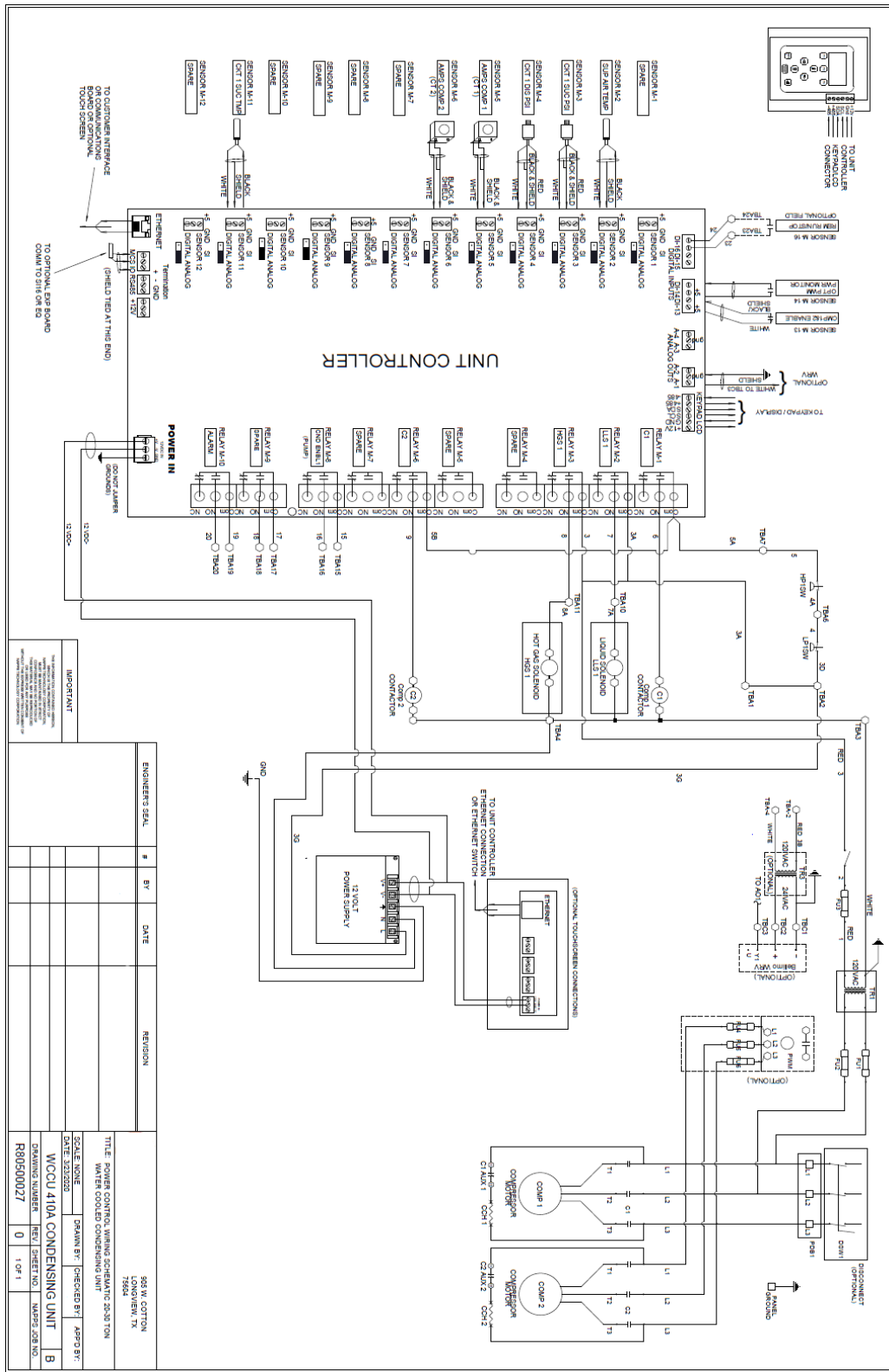

Dual Circuit WCCU Wiring Diagram

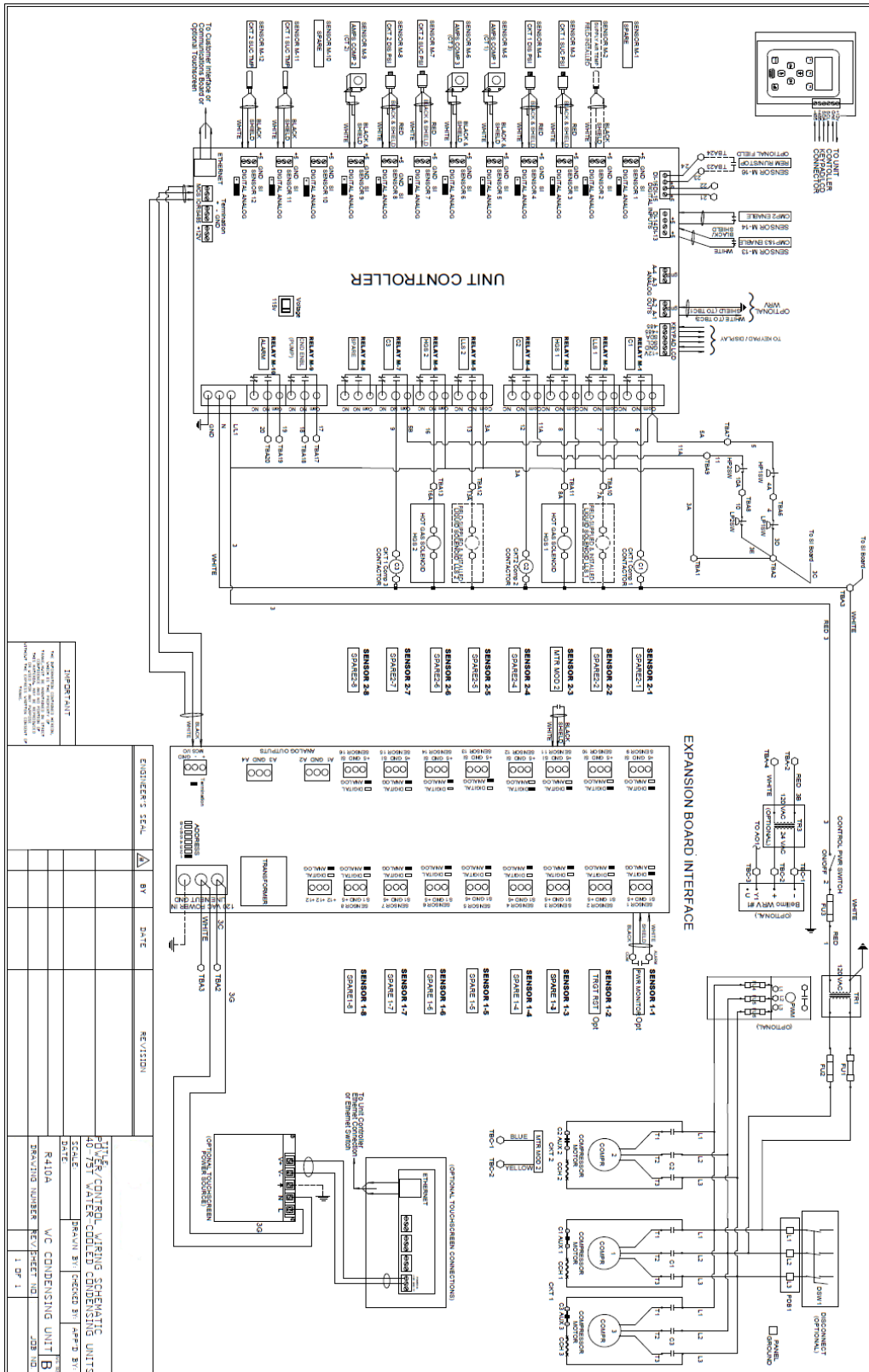

Field Wiring Diagram

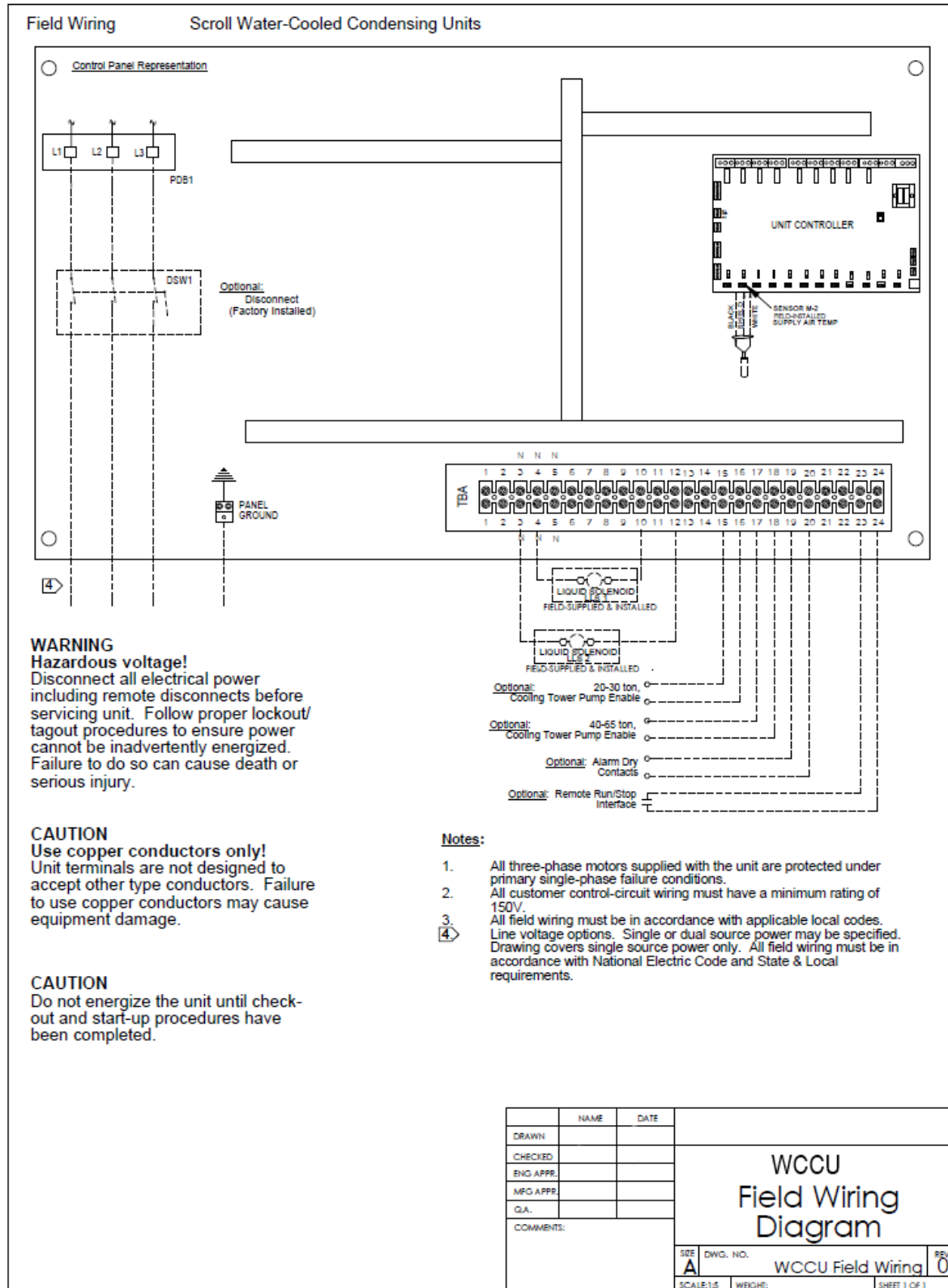

Water Flow vs. Pressure Drop

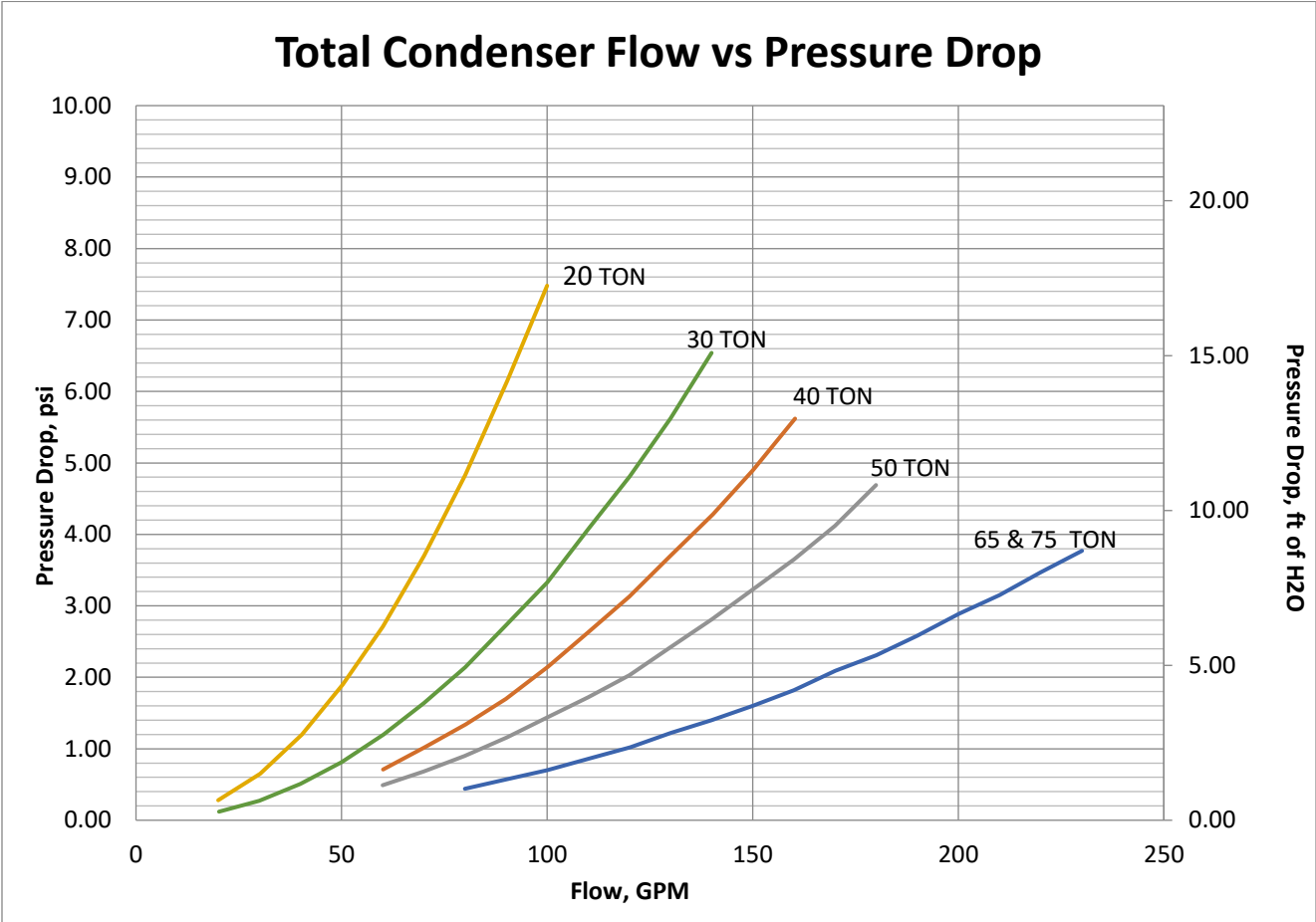

I. LIMITED PRODUCT WARRANTY & SERVICE POLICY

Napps Technology Corporation (NTC) warrants for a period of twelve (12) months from date of original shipment that all products, manufactured by NTC, with the exception of packaged refrigeration products, are free from defects of material and workmanship when used within the service, range, and purpose for which they were manufactured. Packaged refrigeration products shall be so warranted for a period of twelve (12) months from date of start-up or eighteen (18) months from date of original shipment, whichever may first occur. Service Parts shall be so warranted for a period of ninety (90) days from date of installation, or twelve (12) months from date of original shipment, whichever may first occur.

In case material is rejected on inspection by the buyer as defective, NTC shall be notified in writing within ten (10) days from receipt of said material. NTC will then have the option of re-inspection at the buyer's plant or its own plant before allowing or rejecting the buyer's claim. Expenses incurred in connection with claims for which NTC is not liable may be charged back to the buyer. No claim for correction will be allowed for work done in the field except with the written consent of NTC. Defects that do not impair service shall not be cause for rejection. NTC assumes no liability in any event for consequential damages. No claim will be allowed for material damaged by the buyer or in transit. Defective equipment or parts shall be returned to NTC freight prepaid.

NTC will, at its option, repair, replace or refund the purchase price of products found by NTC to be defective in material or workmanship provided that written notice of such defect requesting instruction for repair, replacement or refund is received by NTC within ten (10) days of determination of said defect, but not more than one (1) year after the date of shipment, and provided that any instructions given thereafter by NTC are followed.

Any products covered by this order found to NTC satisfaction to be defective upon examination at NTC factory will, at NTC option, be repaired or replaced and returned to Buyer via lowest cost common carrier, or NTC may, at its option, grant Buyer a credit for the purchase price of the defective article.

This warranty does not cover and does not apply to:

- (1) Fuses, refrigerant, fluids, oil;
- (2) Products relocated after initial installation;
- (3) Any portion or component of the system that is not supplied by NTC, regardless of the cause of the failure of such portion or component;
- (4) Products on which the unit's identification tags or labels have been removed or defaced;
- (5) Products on which payment to NTC is or has been in default;
- (6) Products which have defects or damage which result from improper installation, wiring, electrical imbalance characteristics or maintenance (including, without limitation, defects or damages caused by voltage surges, inadequate voltage conditions, phase imbalance, any form of electrical disturbances, inadequate or improper electrical circuit installation or protection, failure to perform common maintenance, etc.); or are caused by accident, misuse or abuse, fire, the elements, shock, vibration, flood, alteration, misapplication of the product or to any other service, range or environment of greater severity than that for which the products were designed;
- (7) Products which have defects or damage which result from a contaminated or corrosive air or liquid supply, operation at abnormal temperatures, or unauthorized opening of refrigerant circuit;
- (8) Products subjected to corrosion or abrasion or chemicals;
- (9) Mold, fungus or bacteria damage;
- (10) Products manufactured or supplied by others;
- (11) Products which have been subjected to misuse, negligence, vandalism or accidents;
- (12) Products which have been operated in a manner contrary to NTC printed instructions;
- (13) Products which have defects, damage or insufficient performance as a result of insufficient or incorrect system design or the improper application of NTC products;
- (14) Products which have defects or damages due to freezing of the water supply, an inadequate or interrupted water supply, corrosives or abrasives in the water supply, or improper or inadequate filtration or treatment of the water or air supply.
- (15) Water-to-refrigerant heat exchanger for any damage resulting from freezing, fouling, corrosion or clogging.

NTC is not responsible for:

- (1) The costs of any fluids, oils refrigerant or other system components, or the associated labor to repair or replace the same, which is incurred as a result of a defective part covered by NTC Limited Product Warranty;
- (2) The costs of labor, refrigerant, materials or service incurred in removal of the defective part, or in obtaining and replacing the new or repaired part; or,
- (3) Transportation costs of the defective part from the installation site to NTC or the return of any part not covered by NTC Limited Product Warranty.

THE WARRANTY PROVIDED ABOVE IS THE ONLY WARRANTY MADE BY NTC WITH RESPECT TO ITS PRODUCTS OR ANY PARTS THEREFORE AND IS MADE EXPRESSLY IN LIEU OF ANY OTHER WARRANTIES, BY COURSE OF DEALING, USAGES OF TRADE OR OTHERWISE, EXPRESSED OR IMPLIED, INCLUDING BUT NOT LIMITED TO ANY IMPLIED WARRANTIES OF FITNESS FOR ANY PARTICULAR PURPOSE OR OF MERCHANTABILITY UNDER THE UNIFORM COMMERCIAL CODE. IT IS AGREED THAT THIS WARRANTY IS IN LIEU OF AND BUYER HEREBY WAIVES ALL OTHER WARRANTIES, GUARANTEES OR LIABILITIES ARISING BY LAW OR OTHERWISE. NTC SHALL NOT INCUR ANY OTHER, OBLIGATIONS OR LIABILITIES OR BE LIABLE TO BUYER OR ANY CUSTOMER OF BUYER FOR ANY ANTICIPATED OR LOST PROFITS, INCIDENTAL OR CONSEQUENTIAL DAMAGES, OR ANY OTHER LOSSES OR EXPENSES INCURRED BY REASON OF THE PURCHASE, INSTALLATION, REPAIR, USE OR MISUSE BY BUYER OR THIRD PARTIES OF ITS PRODUCTS (INCLUDING ANY PARTS REPAIRED OR REPLACED); AND NTC DOES NOT AUTHORIZE ANY PERSON TO ASSUME FOR NTC ANY OTHER LIABILITY IN CONNECTION WITH THE PRODUCTS OR PARTS THEREFORE. NTC SHALL NOT BE RESPONSIBLE FOR THE LOSS OR REPLACEMENT OF OR THE ADDITION OF COMPRESSOR OIL, OR REFRIGERANT. THIS WARRANTY CANNOT BE EXTENDED, ALTERED OR VARIED EXCEPT BY A WRITTEN INSTRUMENT SIGNED BY NTC AND BUYER.

II. LIMITATION OF LIABILITY

NTC shall not be liable, in contract or in tort, for any special, indirect, incidental or consequential damages, such as, but not limited to, loss of profits, or injury or damage caused to property, products, or persons by reason of the installation, modification, use, repair, maintenance or mechanical failure of any NTC product.

Literature Change History

7/9/2019 – New Literature

3/18/2020 – Added General Data and Pressure Drop Curves

3/24/2020 – Updated wiring diagrams

NTC

Napps Technology Corporation

**905 W. Cotton Street
Longview, TX 75604
Phone: 903-758-2900
www.nappstech.com**

Installation Manual - WCCU Series Revision 200327

It is the intent of NTC to provide accurate up-to-date specification data. However, in the interest of ongoing product improvement, Napps Technology Corporation reserves the right to change specifications and/or design of any product without notice, obligation, or liability.